

End Carriage, Geared Motor, Peripheral Equipment

KITO CRANE

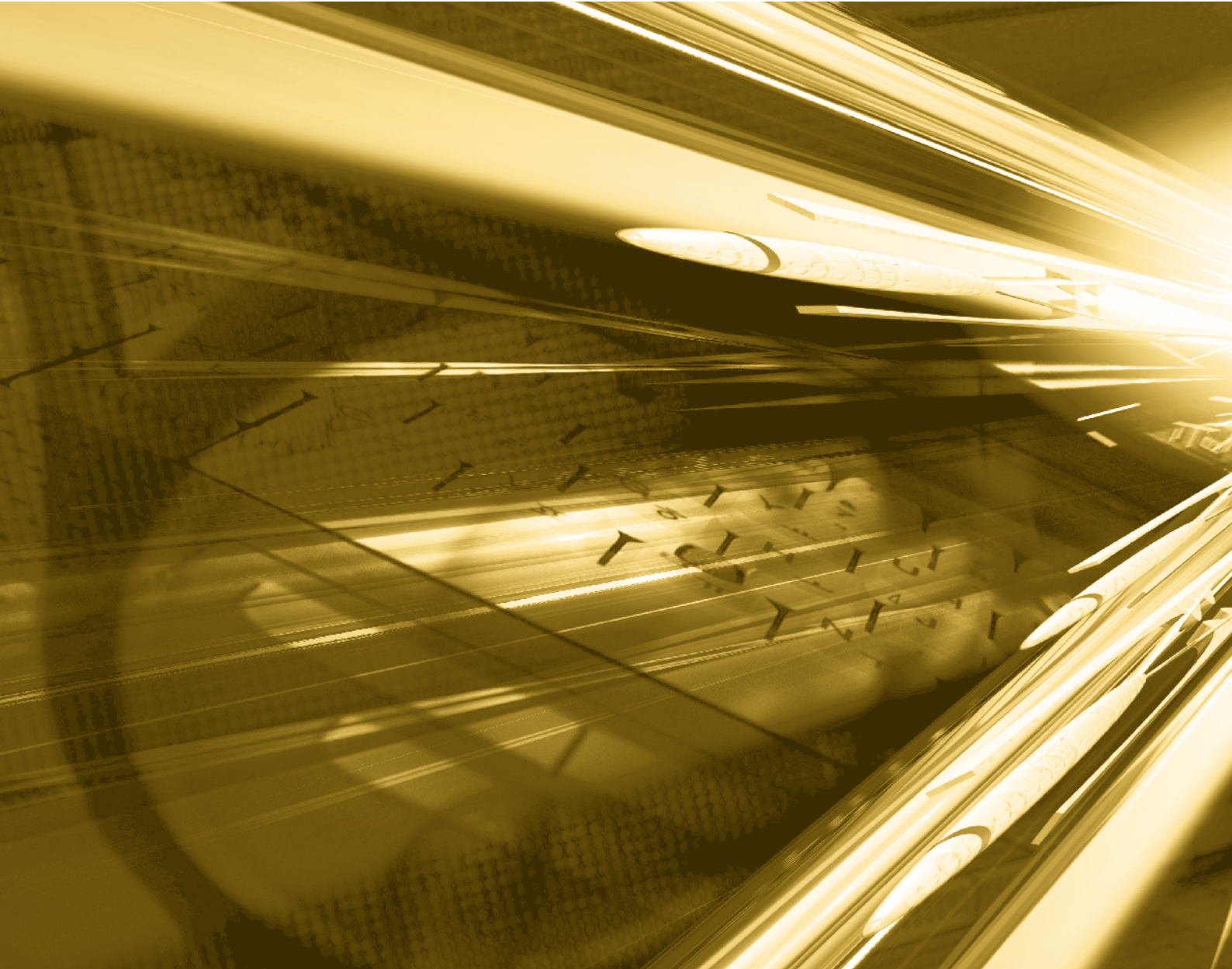

Giving top priority to the every industrial workplace-KITO CRANES.



Cranes are widely used in the workplace to improve work efficiency, to use limited space effectively and to help reduce costs.

To meet the diversifying demands of the industrial world,

KITO manufactures all kinds of cranes from simple manual cranes to motorized cranes with a single or double girder.

All of our products have been designed and built taking into consideration safety, operability and durability.

In addition, we have the cranes which are quiet and vibrate less and which are suitable for a working environment where quiet operation is important.



Table of CONTENTS

KITO Crane Applications	4
Crane Outline	11
End Carriage Capacity	14
Features of End Carriages	15
Geared Motor Capacity	16
Features of Geared Motors	17
End Carriage Specifications	18
Geared Motor Specifications	26
Crane peripheral Equipment Installation Outline	28
Control Boxes	30
SOFTRUN Device	31
Power Supply Cables and Accessories	32
Cable Hangers	33
Crane Girder Allowable Span	34
Reference Examples of Special Specification Systems	35

Note: All measurements used in this catalogue are metric (SI unit system)

KITO

CRANE TEST EQUIPMENT

At KITO, cranes are tested for durability and reliability using special equipment.



Test equipment capacity at KITO factory

Traveling crane	Hoist
Max. test load 50 t	Max. test load 100 t
Span 30 m	

[Overhead cranes]



Overhead cranes

- 1: 30/10 t Double girder
- 2: 2.8 t Single girder
- 3: 20/2.8 t Double girder
- 4: 2.8 t Single girder

KITO CRANE APPLICATIONS

[Overhead cranes]

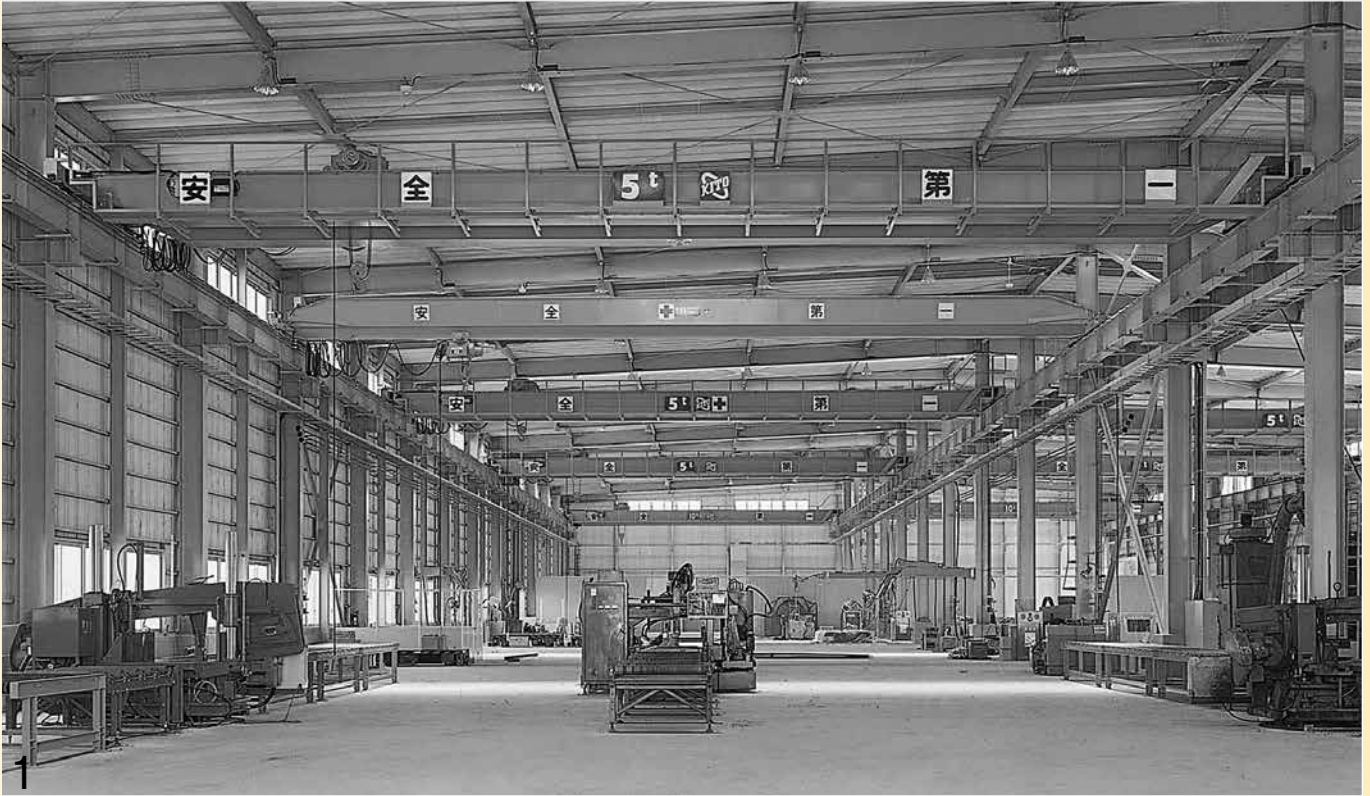

Overhead cranes

- 1: 5 t Double girder
- 2: 10/5 t Double girder



2

[Low-head cranes]

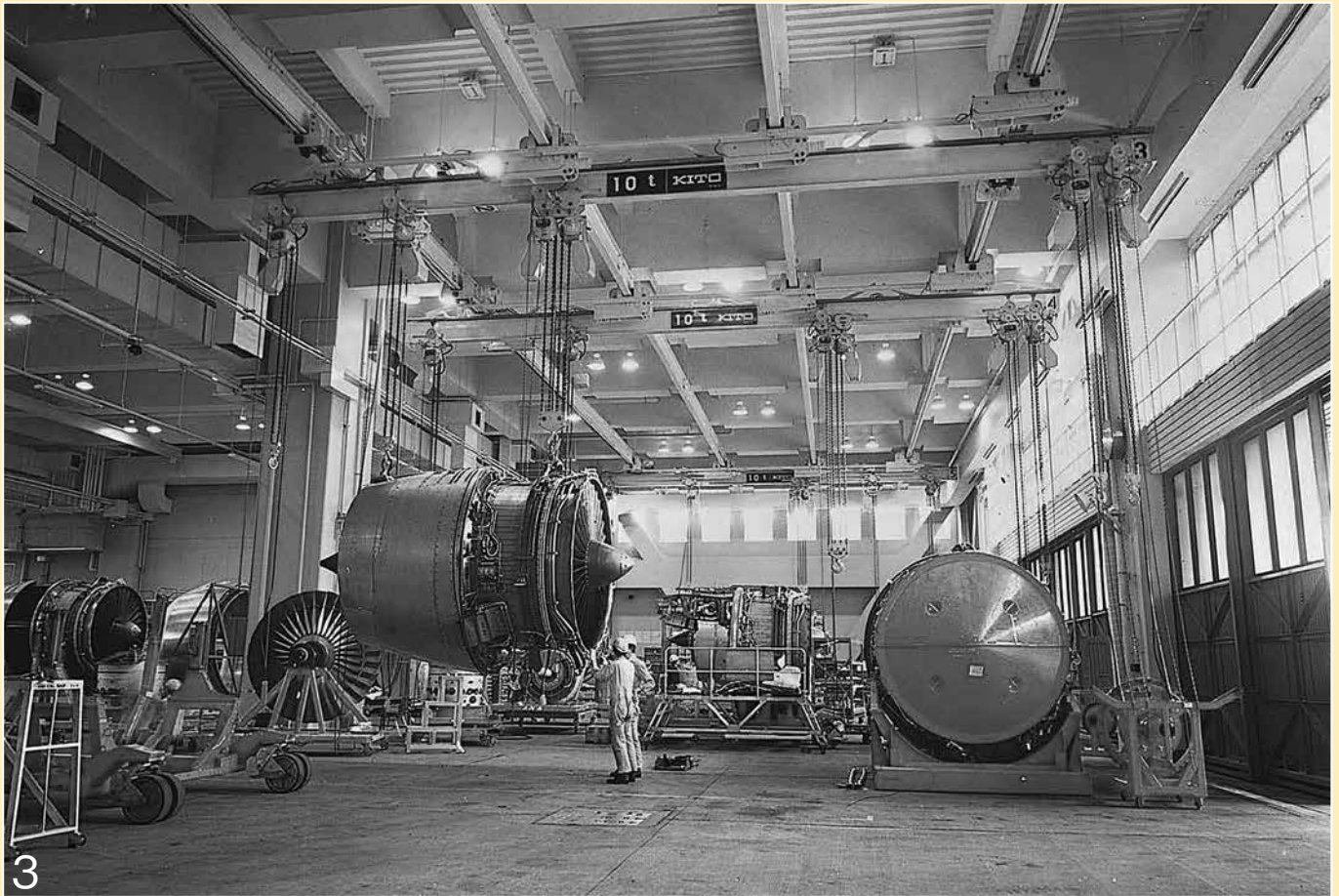

Low-head cranes

3: 10 t Single girder

4: 1 t Single girder

5: 1 t Single girder

KITO CRANE APPLICATIONS

[Gantry cranes]



Gantry cranes

- 1: 20 t Gantry cranes
- 2: 5 t Single leg gentry crane
- 3: 2.8 t Gantry cranes

[Jib cranes]



4



8



5



9



6



10



7

Jib cranes

- 4: 6t Pillar mounted jib crane - auto rotary
- 5: 2t Pillar mounted jib crane
- 6: 2t Pillar mounted jib cranes
- 7: 2t Wall mounted jib crane - auto rotary
- 8: 13t Pillar mounted jib crane - auto rotary
- 9: 2t Wall mounted jib crane - auto rotary
- 10: 1.5t Wall mounted jib cranes - electric traveling

OVERHEAD CRANE [Single Girder]

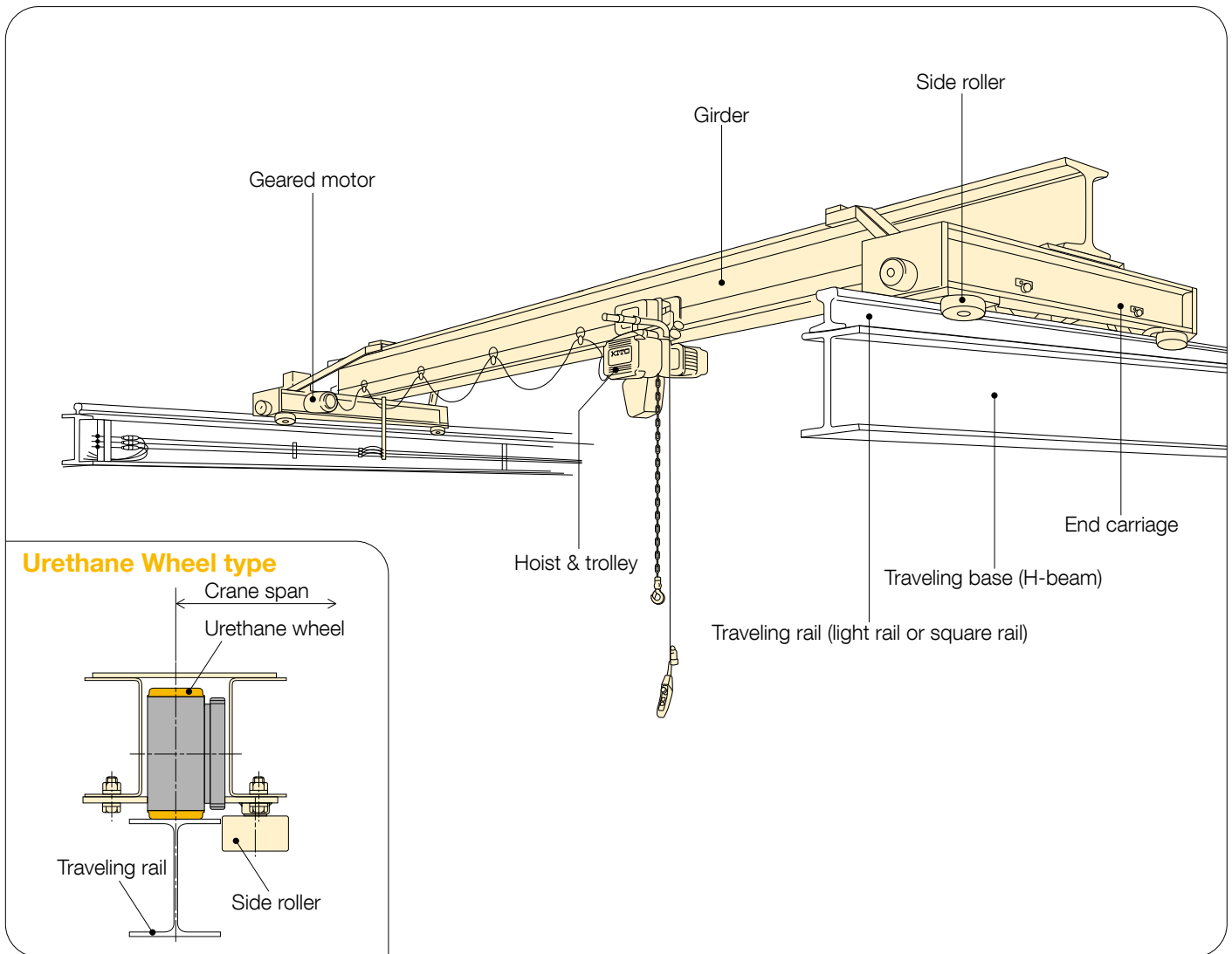

The single girder overhead crane can be installed on traveling rails on the brackets of building pillars. This type of crane has a relatively larger capacity and can utilize space below ceiling rafters, and so a wider lifting range is assured. Guiding the path using side rollers provides smooth traveling and the girders can be designed according to the rated load and span. Moreover, the shorter overall length of the end carriage and the geared-motor installation in optimum position allows for a more effective use of work space.

A dual speed type crane is available for speed-controlled operations. There is also a urethane wheel type version of this crane that effectively reduces noise and vibrations in travel. It is recommended for factories near residential areas, duplex office-homes and for operation at night. Running urethane wheels on the top flange of the H-beam reduces noise and vibration in travel. With these cranes it is not necessary to install a light rail, thus reducing installation costs and time.

Single speed crane

This crane employs geared motors specially designed by KITO to ensure smooth starts and stops. It is suited for general work.

Dual speed crane

This crane is capable of pendant button-controlled speed shift between low and high speed (reduction ratio of 4:1). It is suited for work requiring varied speed operation.

Manual geared type crane

This manual geared type crane balances travel smoothly by synchronizing the driving wheels on both sides. With a relatively shorter travel distance, it is suited for low frequency work.

Optional SOFTRUN device

This device electrically controls motor speed which enables to accelerate smoothly in travel and minimizes load swing at start-up.

It is highly suited for handling high inertia loads or operating long span cranes.

OVERHEAD CRANE [Double Girder]

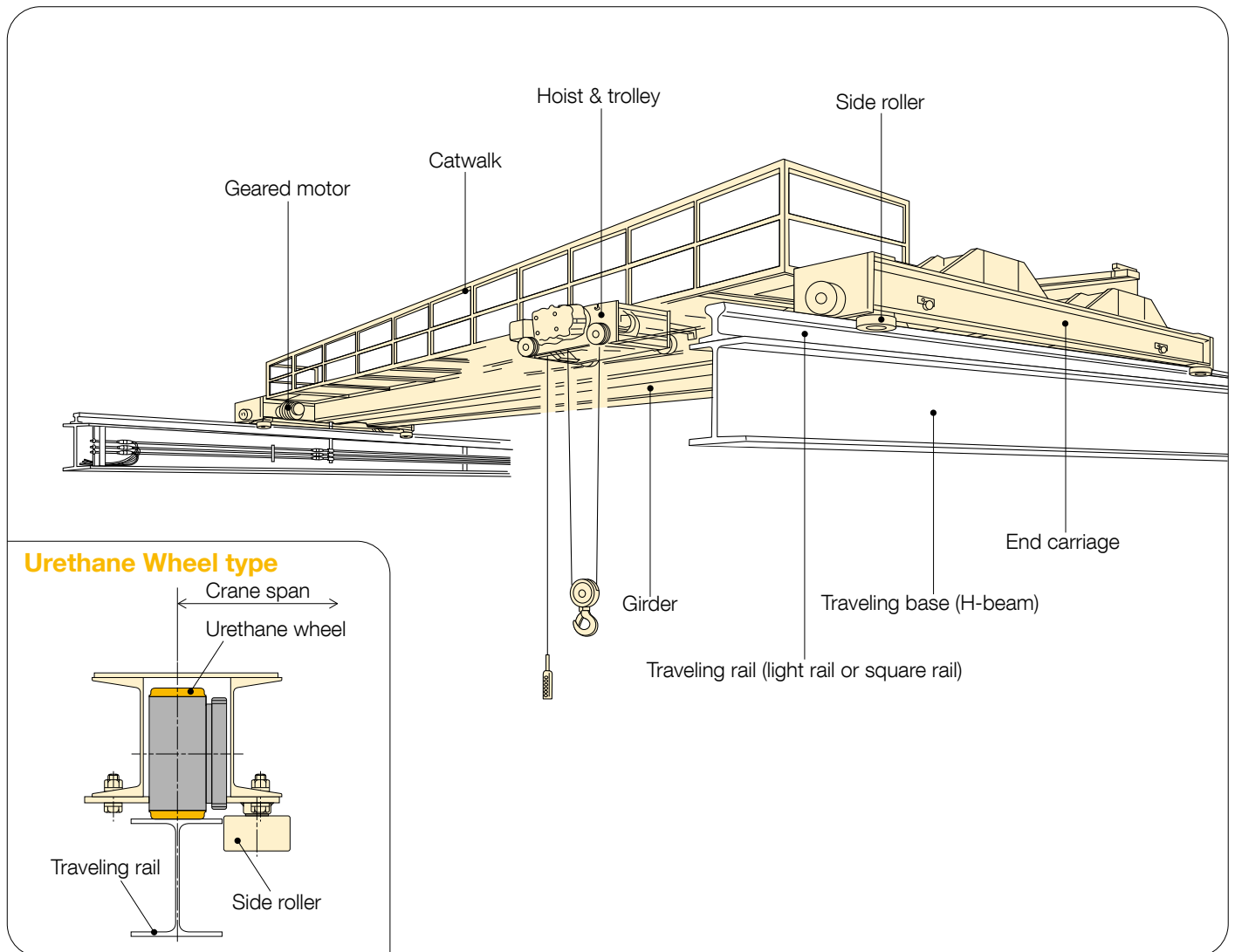

The double girder overhead crane can be installed on traveling rails on the brackets of building pillars. The double rail type trolley runs along parallel girders suitable for larger capacity cranes, and also can utilize space below ceiling rafters, and so a wider lifting range assured. Smooth traveling is obtained using a guide mechanism with side rollers, and the girder construction can be designed according to the rated load and span. Moreover, the shorter overall length of the end carriage allows for a more effective use of the work space.

A dual speed type crane is available for speedcontrolled operations. There is also a urethane wheel type crane that effectively reduces noise vibration in travel. It is recommended for factories near residential areas, duplex office-homes and for operation at night. Running urethane wheels on the top flange of the H-beam reduces noise and vibration in travel. With these cranes, it is not necessary to install a light rail thus reducing on installation costs and time.

Single speed crane

This crane employs geared motors specially designed by KITO to ensure smooth starts and stops. It is suited for general work.

Dual speed crane

This crane is capable of pendant button-controlled speed shift between low and high speed (reduction ratio of 4:1). It is suited for work requiring varied speed operation.

Optional SOFTRUN device

This device electrically controls motor speed which enables to accelerate smoothly in travel and minimizes load swing at start-up.

It is highly suited for handling high inertia loads or operating long span cranes.

LOW-HEAD CRANES

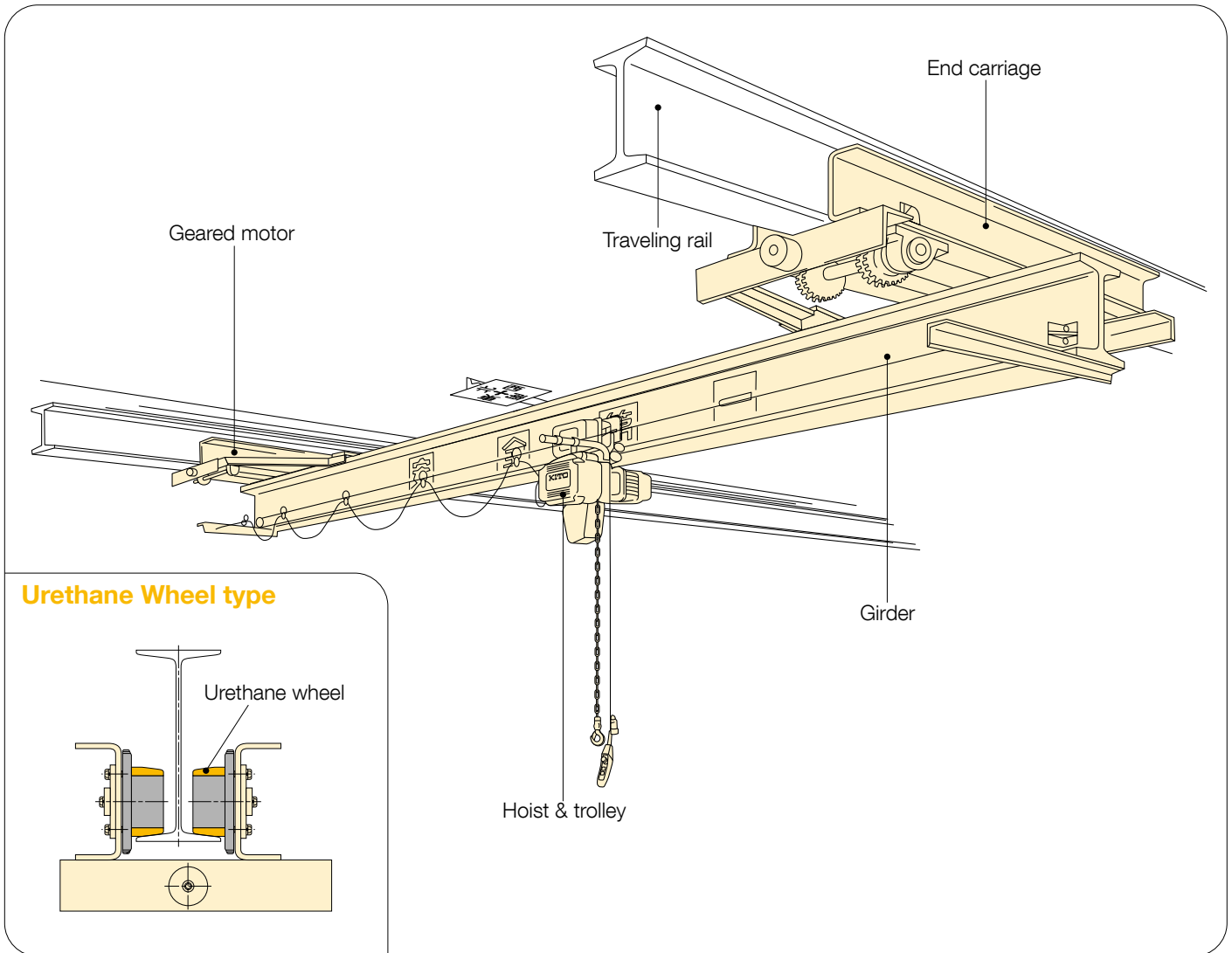

The low-head crane is suspended from the traveling rail (I-beam) which is fixed to the ceiling rafters of the building. Because the traveling rail location and span can be freely chosen, the crane can be designed to suit production line processes. The detaching design for the track wheel and its axle reduces installation and maintenance time.

A dual speed type crane is available for speedcontrolled operation. There is also a urethane wheel type version of the crane that effectively reduces noise and vibration in travel. It is recommended for factories near residential areas, duplex office-homes, and for operation at night.

Single speed crane

This crane employs geared motors specially designed by KITO to ensure smooth starts and stops. It is suited for general work.

Dual speed crane

This crane is capable of pendant button-controlled speed shift between low and high speed (reduction ratio of 4:1). It is suited for work requiring varied speed operation.

Manual geared type

This manual geared type version of the crane balances travel smoothly by synchronizing the driving wheels on both sides. With a relatively shorter travel distance, it is suited for low frequency work.

Manual plain type (Low-head only)

This is the simplest manual type of crane and lifting and traveling are operated by hand. It is suited for light work.

Optional SOFTRUN device

This device electrically controls motor speed which enables to accelerate smoothly in travel and minimizes load swing at start-up. It is highly suited for handling high inertia loads or operating long span cranes.

BRIDGE CRANES

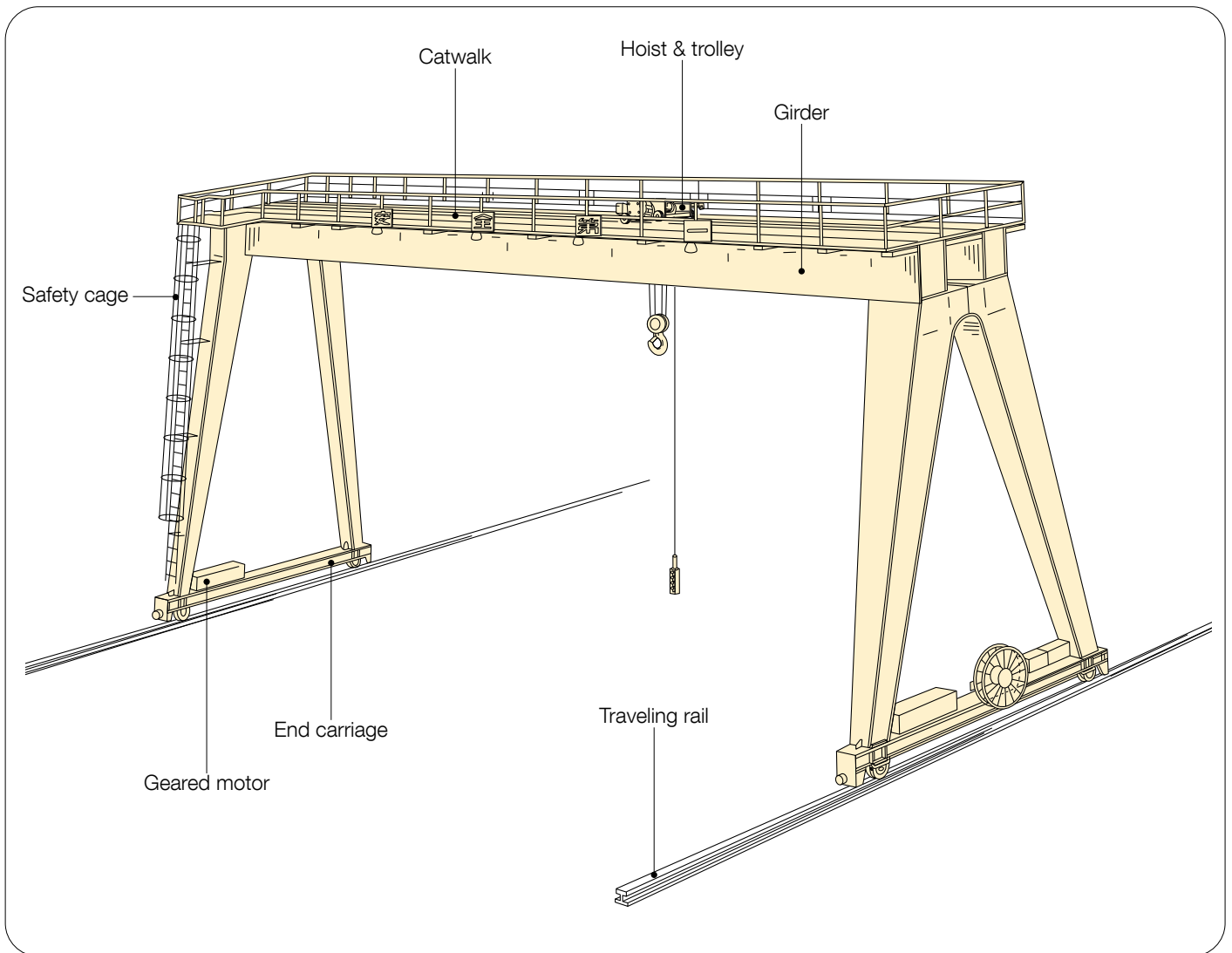

Kito's Gantry Crane Series offer "Gantry Cranes", which run on floor mounted rail by its two legs fabricated from steel sections, and "Single Leg Gantry Cranes", which have the end of the bridge supported by an end truck running on an elevated rail.

It is possible to customize this crane for the work and the installation site. "Gantry Cranes" can be used both outside and inside, and in combination with heavy cranes.

END CARRIAGE CAPACITY

- W.L.L.: indicates the maximum mass (working load limit) for general use.
- Traveling speeds are show on pages 18 to 23.

Type	W.L.L. (t)	Span (m)								Page		
		3	6	9	12	15	18	21	27			
Motorized	Overhead	1	EO010-9		EO010-12	EO010-18		EO010-21		18		
		2	EO020-9		EO020-12	EO020-18		EO020-21				
		3	EO030-9		EO030-12	EO030-18		EO030-21				
		5	EO050-9		EO050-12	EO050-18		EO050-21				
		7.5	EO075-12			EO075-18		EO075-21				
		10	EO100-12			EO100-18		EO100-21				
	Low-head	1	EL010-6	EL010-9	EL010-12	EL010-15					22	
		2	EL020-6	EL020-9	EL020-12	EL020-15						
		3	EL030-6	EL030-9	EL030-12	EL030-15						
		5	EL050-6	EL050-9	EL050-12	EL050-15						
Urethane Wheel Type	Overhead	1	CEO010-9		CEO010-12	CEO010-15	CEO010-18	CEO010-21		19		
		2	CEO020-9		CEO020-12	CEO020-15	CEO020-18	CEO020-21				
		3	CEO030-9		CEO030-12	CEO030-15	CEO030-18	CEO030-21				
		5	CEO050-9		CEO050-12	CEO050-15	CEO050-18	CEO050-21				
		7.5	CEO075-12			CEO075-18		CEO075-21				
		10	CEO100-12			CEO100-18		CEO100-21				
	Low-head	1	CEL010-9								23	
		2	CEL020-9									
Double Girder	Overhead	3	WEO030-15			WEO030-21		WEO030-27		20		
		5	WEO050-15			WEO050-21		WEO050-27				
		7.5	WEO075-15			WEO075-21		WEO075-27				
		10	WEO100-15			WEO100-21		WEO100-27				
		15	WEO150-15			WEO150-21		WEO150-27				
		20	WEO200-15			WEO200-21		WEO200-27				
	Urethane Wheel Type	3	CWEO030-15			CWEO030-21		CWEO030-27		21		
		5	CWEO050-15			CWEO050-21		CWEO050-27				
		7.5	CWEO075-15			CWEO075-21		CWEO075-27				
		10	CWEO100-15			CWEO100-21		CWEO100-27				
		15	CWEO150-15			CWEO150-21		CWEO150-27				
		20	CWEO200-15			CWEO200-21		CWEO200-27				
Manual Type	Overhead	Geared	1	GO010-9		GO010-12					24	
			2	GO020-9		GO020-12						
			3	GO030-9		GO030-12						
			5	GO050-9		GO050-12						
	Low-head	Plain	0.5	PL005-3	PL005-6	PL005-9					25	
			1	PL010-6		PL010-9						
		Geared	1	GL010-6		GL010-12						24
			2	GL020-6		GL020-12						
			3	GL030-6		GL030-12						
			5	GL050-6		GL050-12						

- Optional SOFTRUN is recommended for color models.
- W.L.L.: Working Load Limit (t).

Features of end carriages

- To meet customer needs, we have raised performance while offering more standardized models. The track wheel is now made of a carbon steel construction and is, thus, durable and long-lasting (excluding the plain type crane which is made from heat-treated hot-rolled steel plates)
- Products are primer-coated which allows customers to choose the desired top coat color (KITO Yellow (Equivalent to Munsell 7.2YR6.5/14.5) is painted for plain type cranes).
- Punch-mark on end carriages for easy centering and drilling for girders.

Overhead end carriages	<ul style="list-style-type: none"> ○Track wheel maintenance is easy because of the open frame construction. ○Travel is smooth because of a guide mechanism with side rollers.
Overhead urethane wheel type end carriages	<ul style="list-style-type: none"> ○Durability has been improved with our own developed urethane wheels. ○The urethane wheels run directly over the top flange of the H-beam, thus reducing noise and vibration in travel. It is not necessary to install a light rail thus reducing installation costs and time. ○Travel is smooth because of a guide mechanism with side rollers.
Low-head end carriages	<ul style="list-style-type: none"> ○Both the track wheel and track wheel axle are designed for easy detaching thus reducing installation and maintenance time. ○Anti-drop plates are equipped on the carriage (for CSA).
Low-head urethane wheel type end carriages	<ul style="list-style-type: none"> ○This end carriage employs durable urethane wheels developed by KITO and an idling gear in reinforced nylon resin and reduces noise and vibrations in travel. ○Both the track wheel and track wheel axle are designed for easy detaching thus reducing installation maintenance time.
Manual plain type end carriage	<ul style="list-style-type: none"> ○The hand pulling operation has become smoother and easier with a pressed metal wheel (0.5 t span 3 m and 1 t span 6 m) and side rollers (1 t span 9 m).
Manual geared type end carriage	<ul style="list-style-type: none"> ○Pulling the hand chain makes both wheels move at the same time for balanced smooth traveling.

How to read carriage types

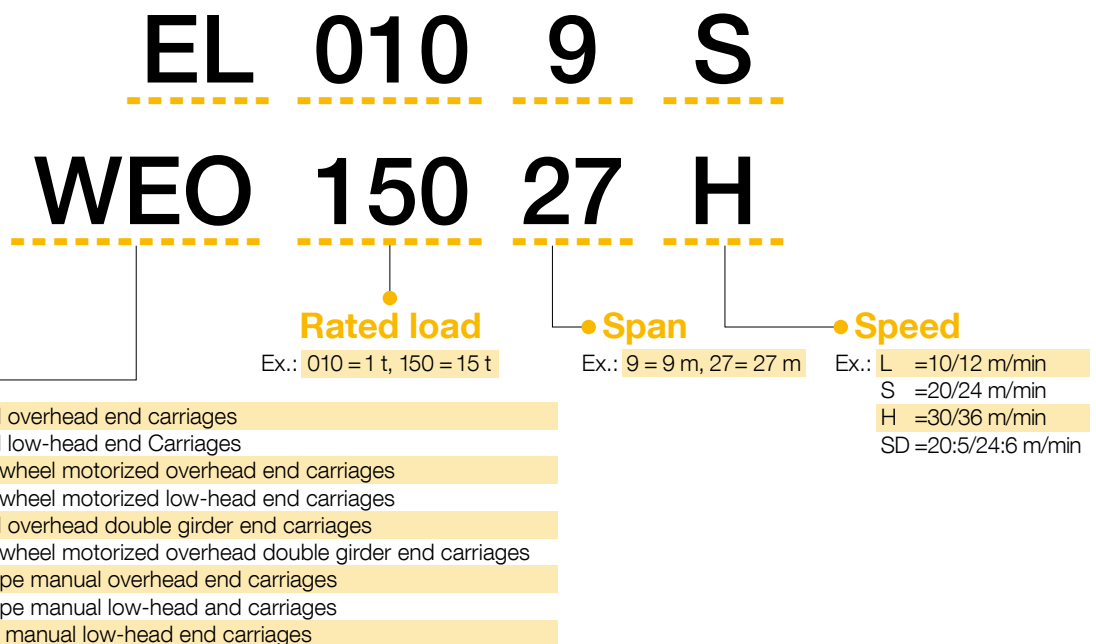

GEARED MOTOR CAPACITY

Type	W.L.L. (t)	Span (m)								
		3	6	9	12	15	18	21	27	
Motorized	Overhead	1	G1MO025□-□				G1MO025□-□		G1MO025□-□	
		2	G1MO025□-□				G1MO025□-□		G1MO040T-□	
		3	G1MO025□-□ G1MO040T-□				G1MO025□-□ G1MO040T-□			
		5	G1MO025□-□ G1MO040T-□			G1MO040□-□ G1MO075T-□				
		7.5	G1MO075□-□ G1MO150T-□				G1MO075□-□		G1MO075□-□	
		10					G1MO150T-□		G1M150T-□	
	Low-head	1	G1ML025□-□		G1ML025□-□	G1ML025□-□	G1ML040□-□	Available on your request		
		2	G1ML025□-□		G1ML025□-□	G1ML025□-□				
		3	G1ML025□-□		G1ML025□-□ G1ML040T-□					
		5	G1ML040□-□ G1ML075T-□			G1ML075□-□				
Urethane Wheel Type	Overhead	1	G1MO025□-□				G1MO040□-□		G1MO075□-□	
		2	G1MO040□-□						G1MO075□-□	
		3	G1MO075□-□							
		5	G1MO075□-□ G1MO150T-□				G1MO150□-□		G1MO150□-□	
		7.5	G1MO150□-□				G1MO150□-□			
		10					G1MO150□-□ G1MO150□-□x2			
	Low-head	1	G1ML025□-□				Available on your request			
2	G1ML040□-□ G1ML075T-□									
Double Girder	Overhead	3	G1MO025□-□ G1MO040T-□						G1MO040□-□ G1MO075T-□	
		5	G1MO040□-□ G1MO075T-□				G1MO075□-□ G1MO150T-□		G1MO075□-□ G1MO150T-□	
		7.5	G1MO075□-□						G1MO075□-□ G1MO150T-□	
		10	G1MO150T-□				G1MO075□-□ G1MO150T-□		G1MO150□-□	
		15	G1MO150□-□							
		20	G1MO150□-□ G1MO150□-□x2				G1MO150□-□ G1MO150□-□x2			
	Urethane Wheel Type	3	G1MO075□-□ G1MO150T-□						G1MO150□-□	
		5	G1MO150□-□							
		7.5	G1MO150□-□							
		10	G1MO150□-□x2				G1MO150□-□x2			
15	G1MO150□-□x2				G1MO150□-□x2					
20	G1MO150□-□x2				G1MO150□-□x2		G1MO150□-□x2			

- 1.5 kWx2 means 2 geared motors are used on 1 end carriage (on side): 4 driving motor type.
- For dual listings, models on the upper line are the low, standard and dual speeds end carriages, whereas models on the lower line are the high speed end carriages. Single listings show the low, standard, high and dual speed end carriages.
- *Available on request (2.2 kWx2 for 30/36 m/min. speed).
- W.L.L.: Working Load Limit (t).

Features of geared motors

- KITO cranes employ a geared motor with an electromagnetic brake. Brake torque is adjustable from 0 to 50% (for 0.25 kW :from 30 to 80%) of the rated torque of the motor, thus the load swing can be minimized by adjusting the brake torque.
- The motor uses a helical gear, which reduces noise during operation.
- SOFTRUN devices are available to provide smooth starts and minimize swing.
- Motors are available in three different single speed (10/12, 20/24, and 30/36 m/min 50/60 Hz) types and one dual speed (20/5 24/6 m/min 50/60 Hz) type (reduction ratio of 4:1) and they make work more efficient.

How to read types (example)

G1MO025 L-E

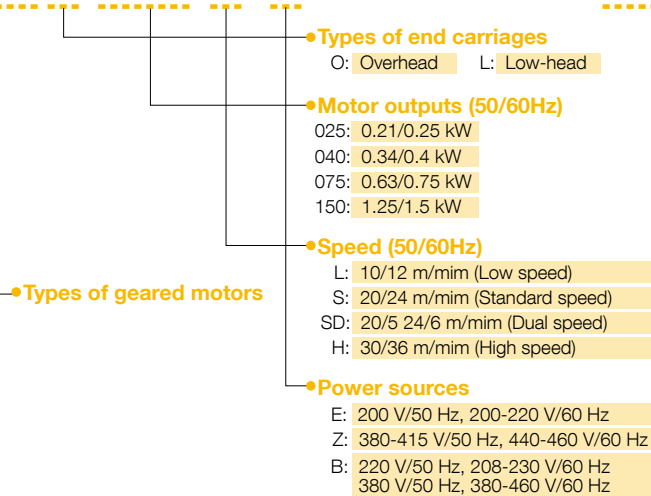

G1MO040 T-Z

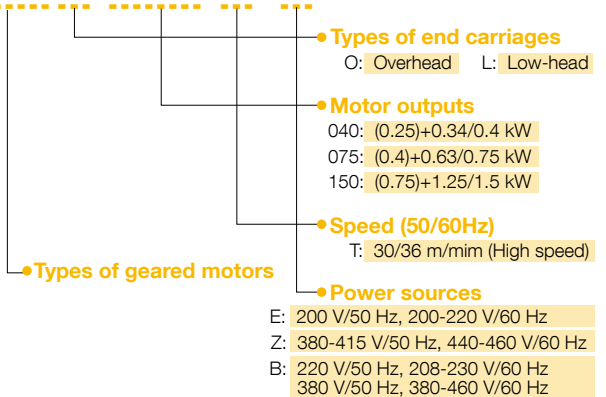

How to order end carriages (example)

When ordering an end carriage and geared motor separately

Ex. Overhead end carriage 1 t span 12 m.

Geared motor for traveling speed 20 m/min, motor output 0.25 kW, and electric voltage 380 V 50 Hz.

- **End carriage**

EO010-12 shown on page 18

- **Geared motor**

G1MO025S-Z shown on page 26

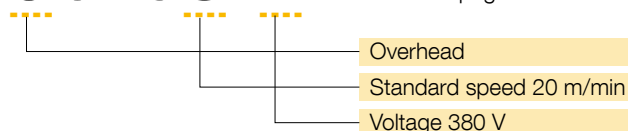

When ordering an end carriage and geared motor as a complete unit

Ex. Overhead end carriage 1 t span 12 m, traveling speed 20 m/min and electric voltage 380 V 50 Hz.

- **Complete unit**

EO010-12-S-Z shown on page 18

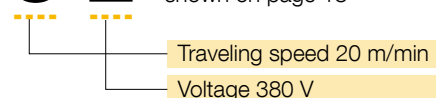

END CARRIAGE SPECIFICATIONS

Motorized Overhead End Carriage Specifications

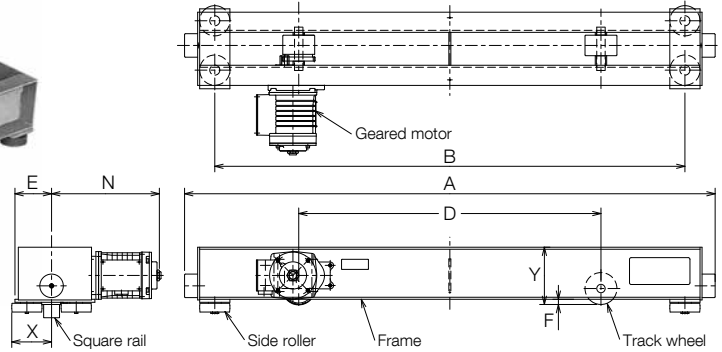

Ex. Above photo shows EO030-12
Some types of motors are mounted in parallel on the frames.

W.L.L. (t)	Max. span (m)	Type	Traveling motor output (kWx2) 50/60 Hz (m/min)				Applicable square rail (mm)	Max. wheel pressure (kN)	Wheel diameter (mm)	Dimensions (mm)							Mass (kg/set)	
			L	S	H	SD				A	B	D	E ^{*1}	F	N ^{*2}	X		Y
			10/12	20/24	30/36	20:5/24:6												
1	9	EO010-9																
	12	☆EO010-12			0.21/0.25		□32-□40 □38-□45	9.31	95	1580	1400	900	109	15.5	321	119	171	132
	18	EO010-18						17.6	125	2280	2100	1200	124		325		191	197
	21	EO010-21			0.34/0.4		□45-□50	31.4	175	2691	2505	1400	144		326	123	221	380
2	9	EO020-9																
	12	☆EO020-12			0.21/0.25		□32-□40 □38-□45	17.6	125	1580	1400	900	114		325	119	176	146
	18	EO020-18	0.21/0.25	0.21/0.25		0.21:0.053/ 0.25:0.063				2280	2100	1200	124	20.5			221	212
	21	EO020-21						31.4	175	2691	2505	1400	144		326		221	380
3	9	EO030-9																
	12	☆EO030-12			0.34/0.4		□45-□50	20.6	140	1580	1400	900	114		325	123	176	150
	18	EO030-18						23.5	155	2280	2100	1200	149				221	252
	21	EO030-21						31.4	175	2691	2505	1400	144		326		221	380
5	9	☆EO050-9								1490	1300	800	124		323			197
	12	EO050-12					□50			2296	2100	1200	138			143	224	374
	18	EO050-18	0.34/0.4	0.34/0.4	0.63/0.75	0.34:0.084/ 0.4:0.1		44.1	210	2296	2100	1200	138		376			264
	21	EO050-21								2696	2500	1400	163				264	496
7.5	12	☆EO075-12						73.5	250	1645	1405	900	138				224	384
	18	EO075-18								2345	2105	1200	163	23.5			264	586
	21	EO075-21						79.4	300	2745	2505	1400	183				324	724
10	12	☆EO100-12	0.63/0.75	0.63/0.75	1.25/1.5	0.63:0.16/ 0.75:0.19	□55-□60	73.5	250	1645	1405	900	138		445	162	224	384
	18	EO100-18								2345	2105	1200	163				264	586
	21	EO100-21						79.4	300	2745	2505	1400	183				324	724

•W.L.L.: Working Load Limit (t).
 *1: The size including the projection of the side roller plate.
 *2: The size with the standard speed (s) geared motor.
 ☆: Geared motors installed in diagonal positions as shown in the above photo.
 •When planning a girder or cart, contact your nearest Kito distributor.

Urethane Wheel Motorized Overhead End Carriage Specifications

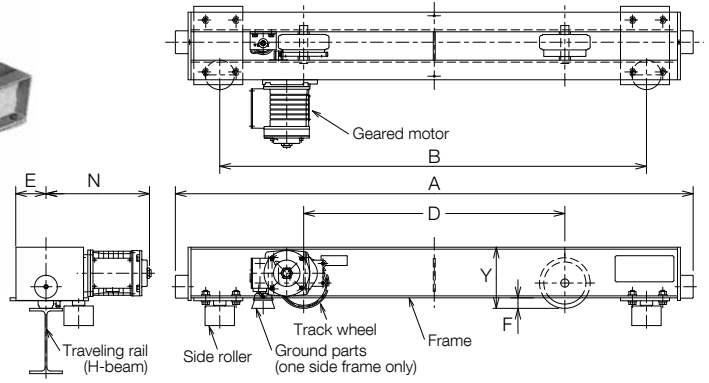

Ex. Above photo shows EO030-15
Some types of motors are mounted in parallel on the frames.

W.L.L. (t)	Max. span (m)	Type	Traveling motor output (kWx2) 50/60 Hz (m/min)				Applicable traveling rail (mm)	Max. wheel pressure (kN)	Recommended wheel pressure (kN)	Wheel diameter (mm)	Dimensions (mm)							Mass (kg/set)	
			L	S	H	SD					A	B	D	E ^{*4}	F	N ^{*5}	Y		
			10/12	20/24	30/36	20:5/24:6													
1	9	☆CEO010-9	0.21/0.25	0.21/0.25	0.21/0.25	0.21:0.053/ 0.25:0.063	100-125-150	7.8	7.4	155	1586	1307	800	110		317	188	156	
	12	☆CEO010-12									1696	1445	900		32		202		
	15	CEO010-15	0.34/0.4	0.34/0.4	0.34/0.4	0.34:0.084/ 0.4:0.1		14.7	13.9	175	2356	2105	1200			383	233	265	
	18	CEO010-18																	
	21	CEO010-21	0.63/0.75	0.63/0.75	0.63/0.75	0.63:0.16/ 0.75:0.19		33.3	25.0	220	2792	2499	1400	155	39	460	239	502	
2	9	CEO020-9									1696	1445	900	131	32	383	188	202	
	12	☆CEO020-12	0.34/0.4	0.34/0.4	0.34/0.4	0.34:0.084/ 0.4:0.1		14.7	13.9	175	2082	1761	1000					384	
	15	CEO020-15									2422	2101	1200					398	
	18	CEO020-18									2792	2499	1400					502	
	21	CEO020-21																	
3	9	CEO030-9			0.63/0.75														
	12	CEO030-12									2082	1761	1000					384	
	15	CEO030-15	0.63/0.75	0.63/0.75		0.63:0.16/ 0.75:0.19	150-175-200	33.3	25.0	220				155		460		239	
	18	CEO030-18									2422	2101	1200					398	
	21	CEO030-21									2792	2499	1400					502	
5	9	CEO050-9									1852	1531	900		39			355	
	12	☆CEO050-12																	
	15	CEO050-15						41.2	31.0	260	2402	2106	1200	153		559		543	
	18	CEO050-18																	
	21	CEO050-21			1.25/1.5						2821	2506	1400	184				279	665
7.5	12	☆CEO075-12									2081	1766	900	177				239	525
	18	CEO075-18	1.25/1.5	1.25/1.5		—		61.7	46.2	340	2421	2106	1200	184		553		279	627
	21	CEO075-21									2821	2506	1400						665
10	12	☆CEO100-12									2081	1766	900	177				239	525
	18	CEO100-18																	
	21	☆CEO100-21			1.25/1.5x2		200-250	81.3	60.0	440	2849	2509	1400	234	46	592	346	1027 (1220)	

•W.L.L.: Working Load Limit (t). •Weight in parentheses is for high speed (H). *1: Contact your nearest Kito distributor for sizes other than listed above.
*2: Wheel pressure under the W.L.L. beneath the end carriage with standard girder and maximum span to verify endurance of the structure.
*3: In case of regular use of more than 80% of W.L.L. or frequent operation at a particular position, select an end carriage to make the wheel pressure the same as or less than the recommended wheel pressure.
*4: The size including the projection of the side roller plate. *5: The size with the standard speed (s) geared motor.
☆: Geared motors installed in diagonal positions as shown in the above photo. •When planning a girder or cart, contact your nearest Kito distributor.

END CARRIAGE SPECIFICATIONS

Motorized Overhead Double Girder End Carriage Specifications

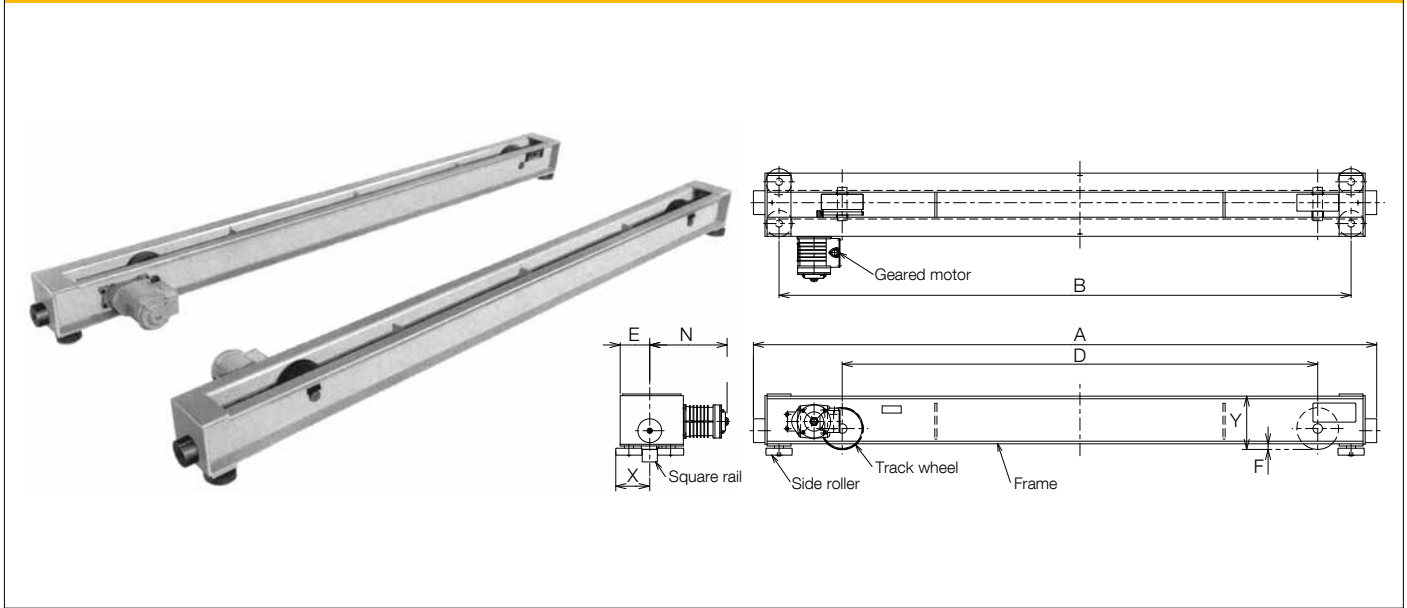

W.L.L. (t)	Max. span (m)	Type	Traveling motor output (kWx2) 50/60 Hz (m/min)				Applicable square rail (mm)	Max. wheel pressure (kN)	Wheel diameter (mm)	Dimensions (mm)							Mass (kg/set)				
			L	S	H	SD				A	B	D	E ^{*1}	F	N ^{*2}	X		Y			
			10/12	20/24	30/36	20:5/24:6															
3	15	WEO030-15	0.21/0.25	0.21/0.25	0.34/0.4	0.21:0.053/ 0.25:0.063	□50	31.4	175	2615	2400	1995	124		325			382			
	21	WEO030-21										2845	2630	2195						449	
	27	WEO030-27	0.34/0.4	0.34/0.4	0.63/0.75	0.34:0.084/ 0.4:0.1						3395	3180	2140	128		375	143	224	504	
5	15	WEO050-15							2845	2630	2195						449				
	21	WEO050-21								3095	2855	2390	134		444			554			
	27	WEO050-27								3425	3185	2590		23.5				736			
7.5	15	WEO075-15					□55·□60	73.5	250	3098	2855	2395					274	686			
	21	WEO075-21	0.63/0.75	0.63/0.75	1.25/1.5	0.63:0.16/ 0.75:0.19											162				
	27	WEO075-27									79.4		3478	3235	2740	138		445		324	799
10	15	WEO100-15						73.5		3098	2855	2395					274	686			
	21	WEO100-21									82.3	300	3288	3045	2540				324	828	
	27	WEO100-27									100	350	3698	3430	2840			529		328	1136
15	15	WEO100-15																			
	21	WEO150-21																			
	27	WEO150-27	1.25/1.5	1.25/1.5	1.25/1.5x2	—				□55·□60·□65	131	400	4028	3760	3150	150	27.5	530	189		1448 (1588)
20	15	WEO200-15															408				
	21	WEO200-21									162	450	4528	4260	3500			531			1945 (2083)
	27	WEO200-27																			

•W.L.L.: Working Load Limit (t).

•Weights in parentheses are for high speed (H).

*1: The size including the projection of the side roller plate.

*2: The size with the standard speed (s) geared motor.

•When planning a girder or cart, contact your nearest Kito distributor.

Urethane Wheel Motorized Overhead Double Girder End Carriage Specifications

● One motor drive type

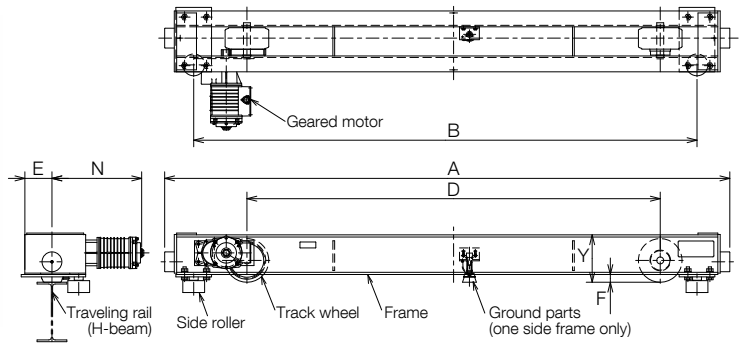

● Two motor drive type (※)

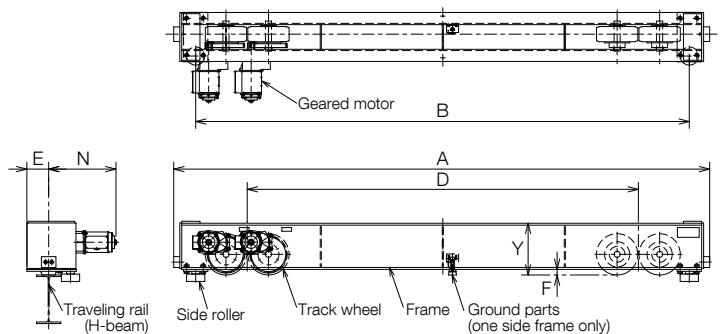

W.L.L. (t)	Max. span (m)	Type	Traveling motor output (kWx2) 50/60 Hz (m/min)				Applicable square rail (mm)	Max. wheel pressure (kN)	Recommended wheel pressure (kN)	Wheel diameter (mm)	Dimensions (mm)						Mass (kg/set)	
			L	S	H	SD					A	B	D	E	F	N		Y
			10/12	20/24	30/36	20:5/24:6												
3	15	CWEO030-15	0.63/0.75	0.63/0.75		0.63:0.16/ 0.75:0.19	33.3	25.0	220	2851	2539	2085	155		459	239	524	
	21	CWEO030-21					41.2	31.0	260	3111	2796	2295	153		560		653	
	27	CWEO030-27	1.25/1.5	1.25/1.5	1.25/1.5		150-175-200	43.1	32.3	300	3211	2896	2140	163		564	289	881
5	15	CWEO050-15					41.2	31.0	260	3111	2796	2295	153	39	560	239	653	
	21	CWEO050-21					61.7	46.2	340	3091	2776	2230	177		553		930	
	27	CWEO050-27	1.25/1.5x2	1.25/1.5x2	1.25/1.5x2		175-200	41.2	31.0	260x2	3771	3456	2700		149	559	289	1160
7.5	15	CWEO075-15	1.25/1.5	1.25/1.5	1.25/1.5		150-175-200	61.7	46.2	340	3091	2776	2230	177	553			930
	21	CWEO075-21						41.2	31.0	260x2	3771	3456	2700	149	559		1160	
	27	CWEO075-27					175-200	43.1	32.3	300x2	4059	3701	2900	159	46	564	346	1438
10	15	CWEO100-15					175-200	41.2	31.0	260x2	3771	3456	2700	149	39	559	289	1160
	21	CWEO100-21						43.1	32.3	300x2	4059	3701	2900	159		564	346	1438
	27	CWEO100-27	1.25/1.5x2	1.25/1.5x2		—					4412	4063	3220			426	1672	
15	15	CWEO150-15					200-250	61.7	46.2	340x2	3992	3643	2790	180		554	346	1378
	21	CWEO150-21									4412	4063	3220				1672	
	27	CWEO150-27			—						5172	4823	3800			593		2575
	27	CWEO150-27H	—	—	2.2x2						5292	4943	3840		46	709		2696
20	15	CWEO200-15	1.25/1.5x2	1.25/1.5x2	—						4742	4393	3380		46	593		2214
	15	CWEO200-15H	—	—	2.2x2						4872	4523	3420			709	426	2332
	21	CWEO200-21	1.25/1.5x2	1.25/1.5x2	—		250-300	81.3	60.0	440x2	5172	4823	3800	212		593		2575
	21	CWEO200-21H	—	—	2.2x2						5292	4943	3840			709		2696
	27	CWEO200-27	1.25/1.5x2	1.25/1.5x2	—						5422	5073	4070			593		2944
	27	CWEO200-27H	—	—	2.2x2						5552	5203	4110			709		3067

●W.L.L.: Working Load Limit (t).

*1: Contact your nearest Kito distributor for sizes other than listed above.

*2: Wheel pressure under the W.L.L. beneath the end carriage with standard girder and maximum span to verify the endurance of the structure.

*3: In case of regular use of more than 80% of W.L.L. or frequent operation at a particular position, select an end carriage to make the wheel pressure the same as or less than the recommended wheel pressure.

*4: The size including the projection of the side roller plate.

*5: The size with the standard speed (s) geared motor.

●When planning a girder or cart, contact your nearest Kito distributor.

END CARRIAGE SPECIFICATIONS

Motorized Low-head End Carriage Specifications

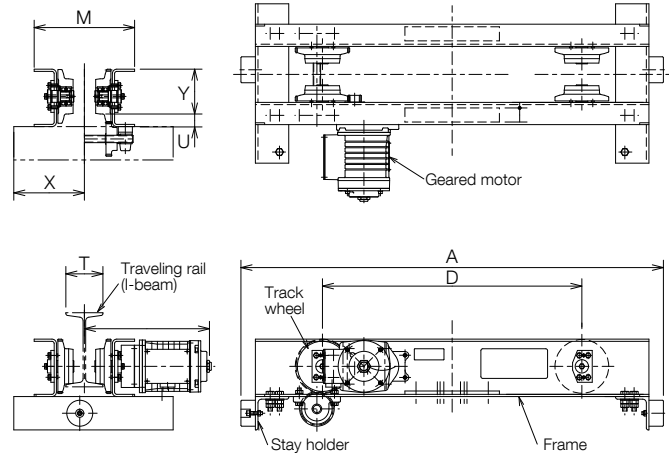

W.L.L. (t)	Max. span (m)	Type	Traveling motor output (kWx2) 50/60 Hz (m/min)				Applicable traveling rail (mm)	Max. wheel pressure (kN)	Wheel diameter (mm)	Dimensions (mm)						Mass (kg/set)	
			L	S	H	SD				A	D	M	U	N ^{*1}	X		Y ^{*2}
			10/12	20/24	30/36	20:5/24:6											
1	6	EL010-6							1140	700							132
	9	EL010-9	0.21/0.25	0.21/0.25	0.34/0.4(B) 0.21/0.25(E,Z)	0.21:0.053/ 0.25:0.063	75-100-125-150	4.51	95	1500	1060	T+171	34	288+T/2	241-T/2	121	150
	12	EL010-12							1840	1400							164
	15	EL030-15	0.34/0.4	0.34/0.4	0.63/0.75(B,Z) 0.34/0.4(E)	0.34:0.084/ 0.4:0.1	125-150	15.7	140	2200	1760	T+231	40	336+T/2		174	340
2	6	EL020-6							1140	700							152
	9	EL020-9	0.21/0.25	0.21/0.25	0.34/0.4(B) 0.21/0.25(E,Z)	0.21:0.053/ 0.25:0.063	100-125-150	9.31	110	1500	1060	T+191	36	288+T/2		138	172
	12	EL020-12							1840	1400						165	202
	15	EL030-15	0.34/0.4	0.34/0.4	0.63/0.75(B,Z) 0.34/0.4(E)	0.34:0.084/ 0.4:0.1	125-150	15.7	140	2200	1760	T+231	40	336+T/2		174	340
3	6	EL030-6			0.34/0.4(B) 0.21/0.25(E,Z)			9.31	110	1140	700	T+191	36		281-T/2	165	160
	9	EL030-9	0.21/0.25	0.21/0.25		0.21:0.053/ 0.25:0.063	100-125-150	10.5	125	1840	1400	T+241	38	288+T/2		162	234
	12	EL030-12			0.34/0.4												340
	15	EL030-15			0.63/0.75(B,Z) 0.34/0.4(E)					2200	1760	T+231					340
5	6	EL050-6	0.34/0.4	0.34/0.4		0.34:0.084/ 0.4:0.1		15.7	140				40	336+T/2		174	
	9	EL050-9			0.63/0.75		125-150			1500	1060	T+211					270
	12	EL050-12															
	15	EL050-15	0.63/0.75	0.63/0.75	0.63/0.75(E)	0.63:0.16/ 0.75:0.19(E,Z)		17.6	155	2200	1760	T+279	39	399+T/2	290-T/2	201	432

•W.L.L.: Working Load Limit (t).

*1: The size with the standard speed (s) geared motor.

*2: The height from the track surface of the traveling rail to the top of the end carriage.

•To reinforce a connecting part of the rails with a plate on the rail web, make sure that the plate has a clearance for the end carriage.
(Do not install the plate for 75 mm width rails or on the rail track.)

•Use I-beam for the traveling rail.

•When planning a girder or cart, contact your nearest Kito distributor.

•E: 200V/50Hz, 200-220V/60Hz

•Z: 380-415V/50Hz, 440-460V/60Hz

•B: 220V/50Hz, 208-230V/60Hz

380V/50Hz, 380-460V/60Hz

Urethane Wheel Motorized Low-head End Carriage Specifications

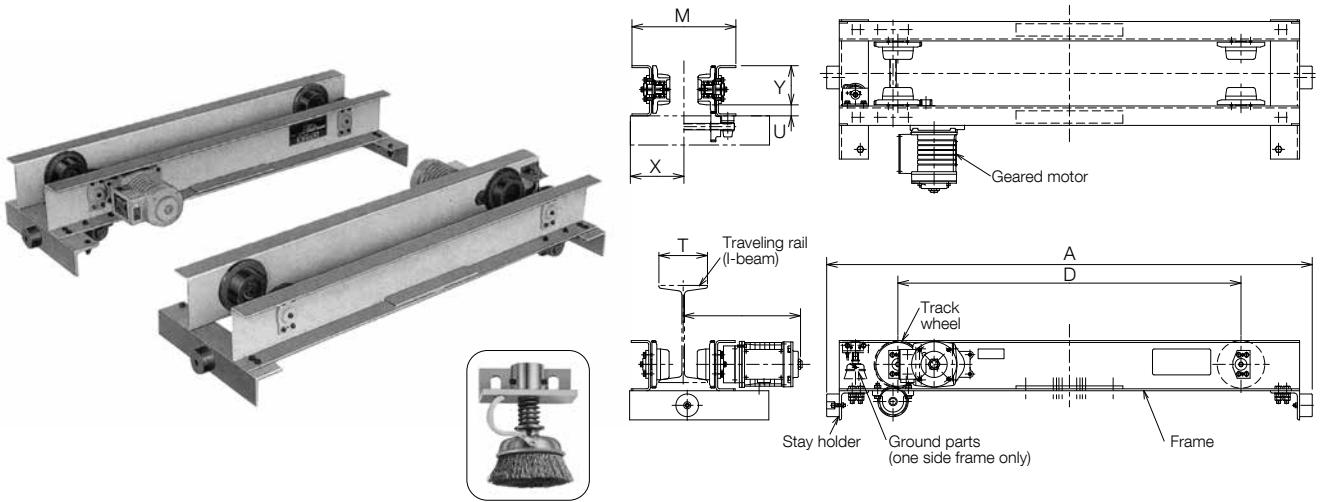

W.L.L. (t)	Max. span (m)	Type	Traveling motor output (kWx2) 50/60 Hz (m/min)				Applicable traveling rail (mm)	Max. wheel pressure (kN)	Recommended wheel pressure (kN)	Wheel diameter (mm)	Dimensions (mm)						Mass (kg/set)	
			L	S	H	SD					A	D	M	U	N ^{*3}	X		Y ^{*4}
			10/12	20/24	30/36	20:5/24:6												
1	9	CEL010-9	0.21/0.25	0.21/0.25	0.34/0.4(B) 0.21/0.25(E,Z)	0.21:0.053/ 0.25:0.063	125-150	3.8	3.6	95	1500	1060	T+171	34	T/2+288	241-T/2	121	143
2	9	CEL020-9	0.34/0.4	0.34/0.4	0.63/0.75	0.34:0.084/ 0.4:0.1		6.7	6.3	125			T+211	35	T/2+336	281-T/2	165	231

•W.L.L.: Working Load Limit (t).

*1: Wheel pressure under the W.L.L. beneath the end carriage with standard girder and maximum span to verify the endurance of the structure.

*2: In case of regular use of more than 80% of W.L.L. or frequent operation at a particular position, select an end carriage to make the wheel pressure the same as or less than the recommended wheel pressure.

*3: The size including the projection of the side roller plate.

*4: The size with the standard speed (s) geared motor.

•To reinforce a connecting part of the rails with a plate on the rail web, make sure that the plate has a clearance for the end carriage. (Do not install the plate for 75 mm width rails or on the rail track.)

•Use I-beam for the traveling rail.

•When planning a girder or cart, contact your nearest Kito distributor.

•E: 200V/50Hz, 200-220V/60Hz

•Z: 380-415V/50Hz, 440-460V/60Hz

•B: 220V/50Hz, 208-230V/60Hz

380V/50Hz, 380-460V/60Hz

Track wheel and track wheel axle construction

With respect to a low-head end carriage, both the track wheel and track wheel axle are designed for easy detaching, thus reducing installation and maintenance time.

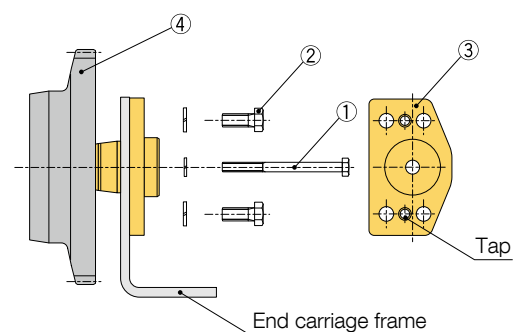
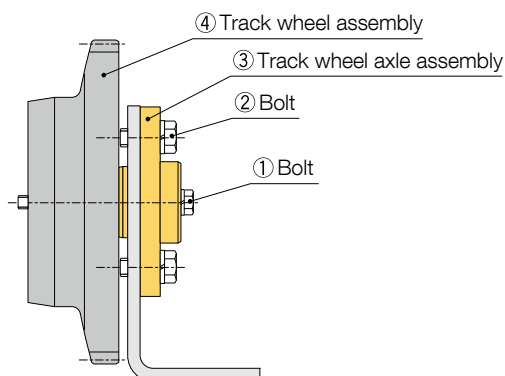

END CARRIAGE SPECIFICATIONS

Geared Overhead End Carriage Specifications

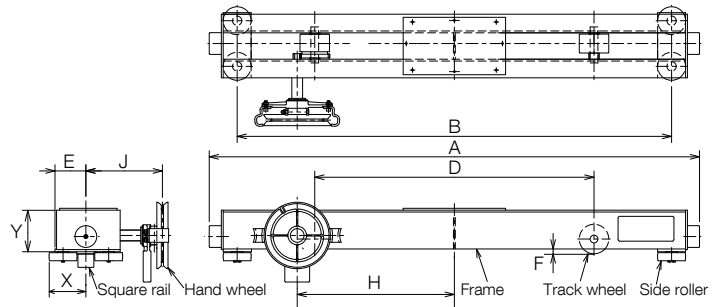

W.L.L. (t)	Max. span (m)	Type	Applicable square rail (mm)	Max. wheel pressure (kN)	Wheel diameter (mm)	Dimensions (mm)								Mass (kg/set)	
						A	B	D	E ^{*1}	F	H	J	X		Y ^{*2}
1	9	GO010-9	□32-□38 □40-□45	9.31	95	1580	1400	900	100	15.5	507	247	119	147	99
	12	GO010-12													
2	9	GO020-9	□45-□50	17.6	125	1580	1400	900	120	15.5	509	252	123	202	130
	12	GO020-12													
3	9	GO030-9	□45-□50	20.6	140	1580	1400	900	135	18.5	521	257	143	205	156
	12	GO030-12													
5	9	GO050-9	□50	44.1	210	1590	1400	900	119	18.5	561	257	143	205	224
	12	GO050-12													

•W.L.L.: Working Load Limit (t).

*1: The size including the projection of the side roller plate.

*2: The height from the track surface of the traveling rail to the top of the end carriage.

•When planning a girder or cart, contact your nearest Kito distributor.

Geared Low-head End Carriage Specifications

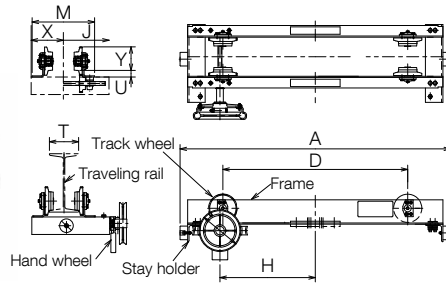

● 1 to 2 t

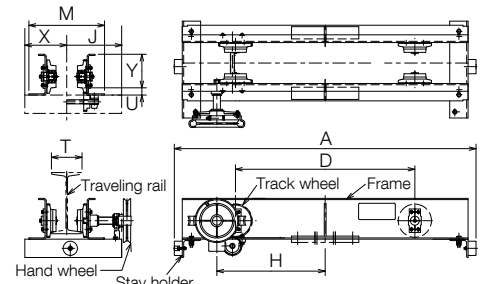

● 3 to 5 t

W.L.L. (t)	Max. span (m)	Type	Applicable traveling rail (mm)	Max. wheel pressure (kN)	Wheel diameter (mm)	Dimensions (mm)								Mass (kg/set)
						A	D	H	J	M	U	J	Y ^{*1}	
1	6	GL010-6	75-100-125-150	4.5	95	1390	950	490	T/2+228	T+171	34	241-T/2	121	106
	12	GL010-12								T+211				
2	6	GL020-6	100-125-150	9.31	110	1480	1030	530	T/2+221	T+191	36	281-T/2	138	142
	12	GL020-12								T+201				
3	6	GL030-6	125-150	10.78	125	1480	880	531.3	T/2+222	T+221	38	315-T/2	165	162
	12	GL030-12								T+231				
5	6	GL050-6	125-150	15.7	140	1480	850	539	T/2+225	T+211	40	315-T/2	174	226
	12	GL050-12								T+249				

•W.L.L.: Working Load Limit (t).

*1: The height from the track surface of the traveling rail to the top of the end carriage.

•To reinforce a connecting part of the rails with a plate on the rail web, make sure that the plate has a clearance for the end carriage. (Do not install the plate for 75 mm width rails or on the rail track.)

•Use I-beam for the traveling rail.

•When planning a girder or cart, contact your nearest Kito distributor.

Plain Low-head End Carriage Specifications

- No side rollers for 0.5 t (max. span 6 m) and 1 t (max. span 6 m)

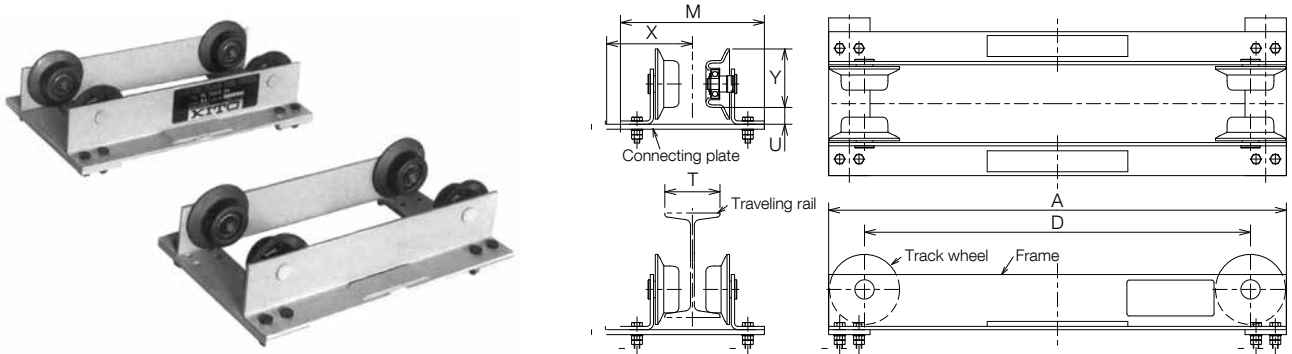

W.L.L. (t)	Max. span (m)	Type	Applicable traveling rail (mm)	Max. wheel pressure (kN)	Wheel diameter (mm)	Dimensions (mm)						Mass (kg/set)	
						A	B	D	M	U	X		Y*
0.5	3	PL005-3	75-100	1.76	71	470		350	T+157	25		89	27
	6	PL010-6	75-100-125	3.5	85	830		700	T+161	31	206-T/2	106	45
1	6	PL010-6											

●W.L.L.: Working Load Limit (t).

*: The height from the track surface of the traveling rail to the top of the end carriage.

●To reinforce a connecting part of the rails with a plate on the rail web, make sure that the plate has a clearance for the end carriage.
(Do not install the plate for 75 mm width rails or on the rail track.)

●Use I-beam for the traveling rail except the size, 100 x 75 x 5.

●When planning a girder or cart, contact your nearest Kito distributor.

Plain Low-head End Carriage Specifications

- Side rollers for 0.5 t and 1 t (max. span 6 m)

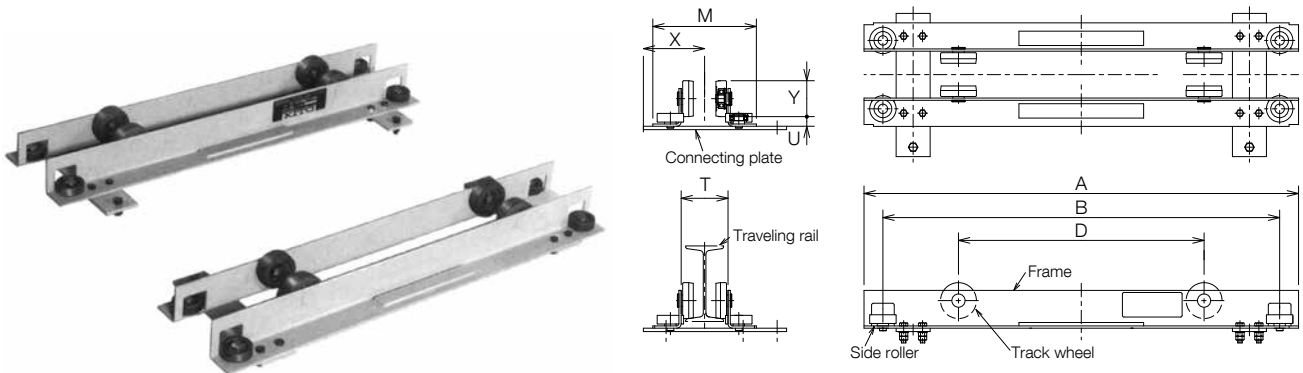

W.L.L. (t)	Max. span (m)	Type	Applicable traveling rail (mm)	Max. wheel pressure (kN)	Wheel diameter (mm)	Dimensions (mm)						Mass (kg/set)	
						A	B	D	M	U	X		Y*
0.5	9	PL010-9	75-100-125	3.92	95	1150	1050	650	T+174	26	212-T/2	95	71
1	9	PL010-9											

●W.L.L.: Working Load Limit (t).

*: The height from the track surface of the traveling rail to the top of the end carriage.

●To reinforce a connecting part of the rails with a plate on the rail web, make sure that the plate has a clearance for the end carriage.
(Do not install the plate for 75 mm width rails or on the rail track.)

●Use I-beam for the traveling rail except the size, 100 x 75 x 5.

●When planning a girder or cart, contact your nearest Kito distributor.

GEARED MOTOR SPECIFICATIONS

■ Dimensions

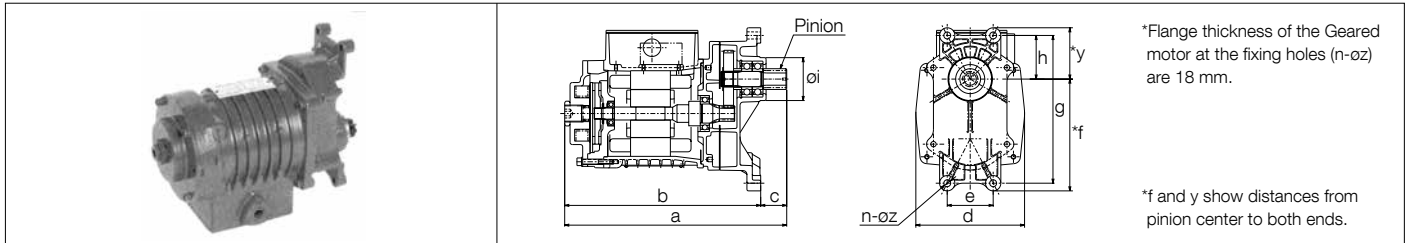

Type	Motor output (kW)		Pole	Power source		Dimensions (mm)											Mass (kg/set)					
	50 Hz	60 Hz		Overhead	Low-head	a		b	c		d	e	f	y	g	h		oi	n	oz		
						Overhead	Low-head		Overhead	Low-head												
G1M□025L-□	0.21	0.25	4	B,E,Z	B,E,Z	290	281	256												67	11	
G1M□025S-□																				82.2		
G1M□025H-□																				67		
G1M□025SD-□	0.21:0.053	0.25:0.063	2/8			324	315	290		25	142	60	146		193	57	56 ⁰ _{-0.046}				70.6	17.5
																					72	
G1M□040T-□	0.34	0.4	4	B,E,Z	B,E,Z	300	291	266	34												75.2	15.5
G1M□040L-□																					78	
G1M□040S-□																					92.6	
G1M□040H-□																					78	
G1M□040SD-□																					78	
G1M□040SD-□	0.34:0.084	0.4:0.1	2/8	B,E,Z	B,E,Z	335	330	301			29	156	70	161		215	66	74 ⁰ _{-0.046}		4	9	15
G1M□040H-□	0.63	0.75	4	B,E,Z	B,E,Z																	

● Brake: DC Disk Brake. ● Brake Torque: From 0 to 50% (for 0.25 kW:30 to 80%) of motor rated Torque. ● Dust and water protection: IP55 (Specified by I.E.C.)

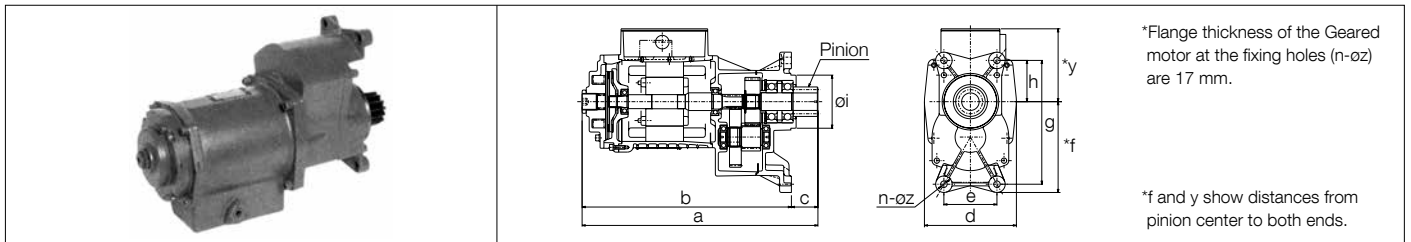

Type	Motor output (kW)		Pole	Power source		Dimensions (mm)											Mass (kg/set)						
	50 Hz	60 Hz		Overhead	Low-head	a		b	c		d	e	f	y	g	h		oi	n	oz			
						Overhead	Low-head		Overhead	Low-head													
G1M□075L-□	0.63	0.75	4	B,E,Z	E	400	393	355														26	
G1M□075S-□																							B,E,Z
G1M□075H-□																							E,Z
G1M□075SD-□	0.63:0.16	0.75:0.19	2/8	B,E,Z	E,Z	415	370	370		45	38	156	90	154	122.6	210	70	90 ⁰ _{-0.054}		4	11	27	
																							30
G1M0150T-□	1.25	1.5	4	E	-	433	426	388														36	
G1M0150L-□																							B,E,Z
G1M0150S-□																							E,Z
G1M0150H-□																							E,Z
G1M0150H-□																							E,Z

● Brake: DC Disk Brake. ● Brake Torque: From 0 to 50% of motor rated Torque. ● Dust and water protection: IP55 (Specified by I.E.C.)

How to read types (example)

G1M025 L-E

- Types of geared motors
- Types of end carriages
 - O: Overhead L: Low-head
- Motor outputs (50/60Hz)
 - 025: 0.21/0.25 kW
 - 040: 0.34/0.4 kW
 - 075: 0.63/0.75 kW
 - 150: 1.25/1.5 kW
- Speed (50/60Hz)
 - L: 10/12 m/mim (Low speed)
 - S: 20/24 m/mim (Standard speed)
 - SD: 20/5 24/6 m/mim (Dual speed)
 - H: 30/36 m/mim (High speed)
- Power sources
 - E: 200 V 50 Hz, 200-220 V 60 Hz
 - Z: 380-415 V 50 Hz, 440-460 V 60 Hz
 - B: 220 V 50 Hz, 208-230 V 60 Hz
 - 380 V 50 Hz, 380-460 V 60 Hz

G1M040 T-E

- Types of geared motors
- Types of end carriages
 - O: Overhead L: Low-head
- Motor outputs
 - 040: (0.25)+0.34/0.4
 - 075: (0.4)+0.63/0.75
 - 150: (0.75)+1.25/1.5
- Speed (50/60Hz)
 - T: 30/36 m/mim (High speed)
- Power sources
 - E: 200 V 50 Hz, 200-220 V 60 Hz
 - Z: 380-415 V 50 Hz, 440-460 V 60 Hz
 - B: 220 V 50 Hz, 208-230 V 60 Hz
 - 380 V 50 Hz, 380-460 V 60 Hz

■ Specifications of Geared Motor Pinions

Type	Motor output (kW)		*Traveling speed (m/min)		*Motor revolutions (r.p.m)		Pinion					
							*Revolutions (r.p.m)		Tooth surface strength (kg)			
	50 Hz	60 Hz	50 Hz	60 Hz	50 Hz	60 Hz	50 Hz	60 Hz	50 Hz	60 Hz	50 Hz	60 Hz
G1M□025L-□			10	12			155	181	158	134	105	90
G1M□025S-□	0.21	0.25	20	24	1410	1650	314	367	78	66	52	44
G1M□025H-□			30	36			463	541	53	45	35	30
G1M□040T-□	0.34	0.4			1430	1700	469	557	83	70	59	47
G1M□025SD-□	0.053	0.063	5	6	730	870	80	91	77	67	51	45
	0.21	0.25	20	24	2960	3530	325	387	75	63	50	42
G1M□040L-□			10	12			132	156	247	208	165	139
G1M□040S-□	0.34	0.4	20	24	1430	1700	255	302	128	107	85	72
G1M□040H-□			30	36			382	453	86	72	57	48
G1M□075T-□	0.63	0.75			1415	1670	378	445	162	137	108	92
G1M□040SD-□	0.084	0.1	5	6	730	860	68	79	121	103	81	68
	0.34	0.4	20	24	2890	3420	266	314	123	103	82	69
G1M□075L-□			10	12			77	91	527	446	323	255
G1M□075S-□	0.63	0.75	20	24	1415	1670	146	173	278	235	158	134
G1M□075H-□			30	36			224	253	182	160	104	92
G1M□150T-□	1.25	1.5			1440	1700	218	256	372	317	—	—
G1M□075SD-□	0.16	0.19	5	6	720	860	39	47	263	219	161	125
	0.63	0.75	20	24	2890	3440	157	187	259	217	159	124
G1MO150L-□			10	12			65	77	1022	862		
G1MO150S-□	1.25	1.5	20	24	1440	1700	127	149	522	446	—	—
G1MO150H-□			30	36			192	227	345	292		

*Figures in the table are approximate values.

■ Details of Pinions

Type	Motor output (kW) 50/60Hz	Pole	Pinion (mm)			
			Module	Number of teeth	x	Outside diameter
G1MO025□-□	0.21/0.25	4		8	0.452	27.1 ⁰ _{-0.1}
G1MO025□-□	0.21:0.053/0.25:0.063	2/8	2.5	12	0.294	36.5 ⁰ _{-0.2}
G1MO040T-□	0.34/0.4	4		8	0.452	27.1 ⁰ _{-0.1}
G1ML040T-□				12	0.294	36.5 ⁰ _{-0.2}
G1MO040□-□	0.34/0.4	4		8	0.460	32.8 ⁰ _{-0.2}
G1ML040□-□	0.34:0.084/0.4:0.1	2/8	3	12	0.294	43.8 ⁰ _{-0.2}
G1MO075T-□	0.63/0.75	4		8	0.460	32.8 ⁰ _{-0.2}
G1ML075T-□				12	0.294	43.8 ⁰ _{-0.2}
G1MO075□-□	0.63/0.75	4	4.5	8	0.550	50 ⁰ _{-0.2}
G1ML075□-□	0.63:0.16/0.75:0.19	2/8	3	21	-0.04	68.8 ⁰ _{-0.2}
G1MO150T-□	1.25/1.5	4	4.5	8	0.550	50 ⁰ _{-0.2}

•Heat treatment: Case hardened HRC: 57 to 63.

•X: Addendum modification coefficient.

■ Brake Torque Adjustment

Torque can be adjusted within a range of 30 to 80% for a 0.25 kW motor and 0 to 50% for motors exceeding 0.4 kW of the rated torque by loosening the lock nut and setting the height of the adjusting bolt. Be sure to tighten the nut and fix the bolt after adjustment. Adjustment is the set-less type.

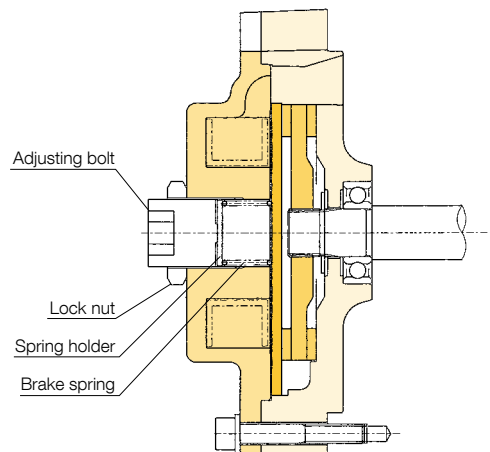

KITO CRANES can be fitted with peripheral equipment for greater durability, higher performance and greater

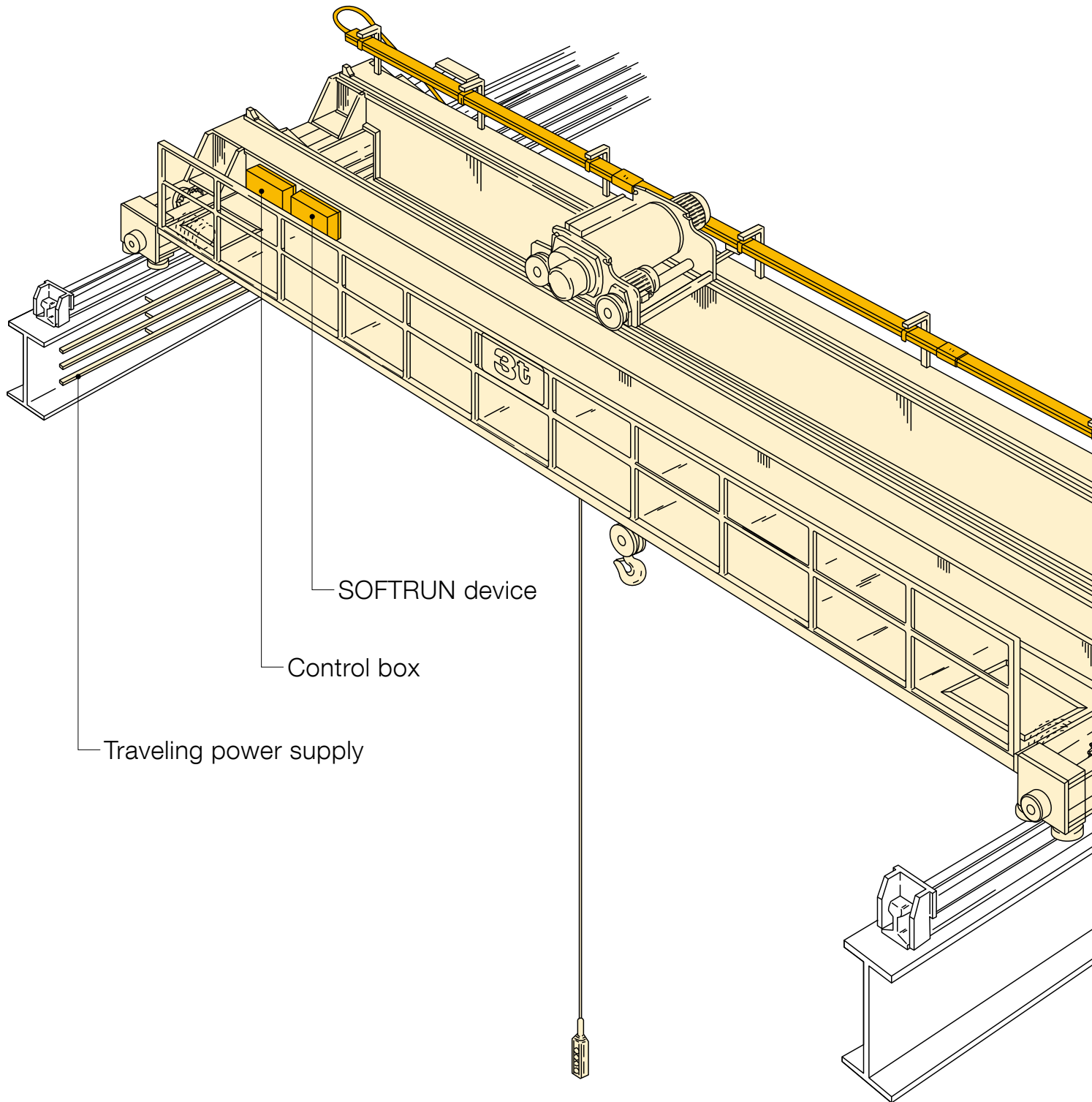

operational efficiency.

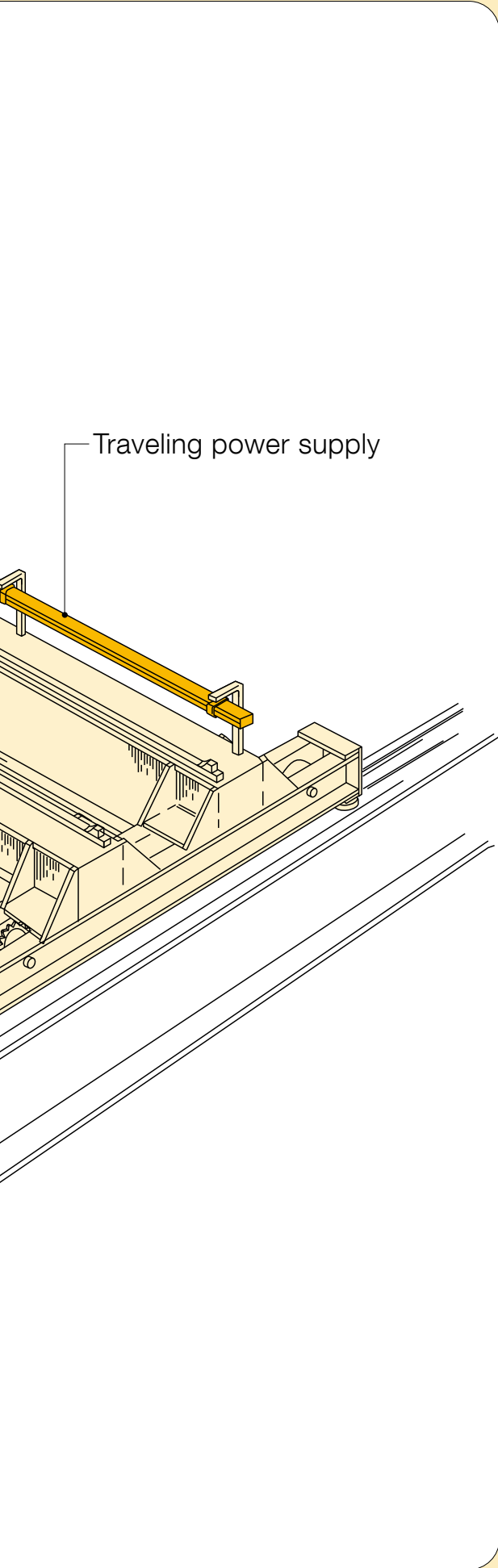

Control Boxes

Dual speed

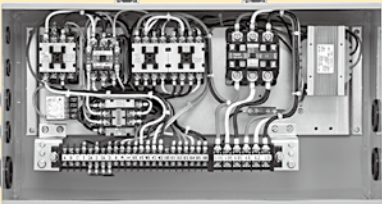

Single speed



For an electric chain hoist with an emergency stop device.

Emergency Stop Device



For an electric chain hoist



For a rope hoist (option)

SOFTRUN Device (option)

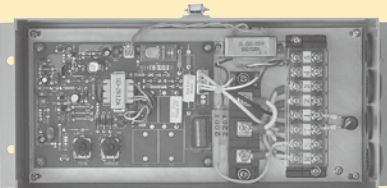

CONTROL BOXES

For electric chain hoist (ER2M)

This control box includes a built-in electromagnetic contactor and a transformer with control voltage of 24V. Other control voltages are available as an option. All models are equipped with an emergency stop device as standard.

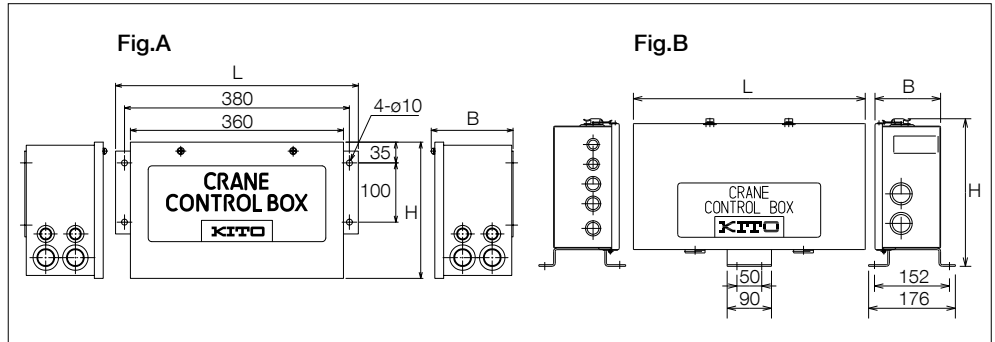
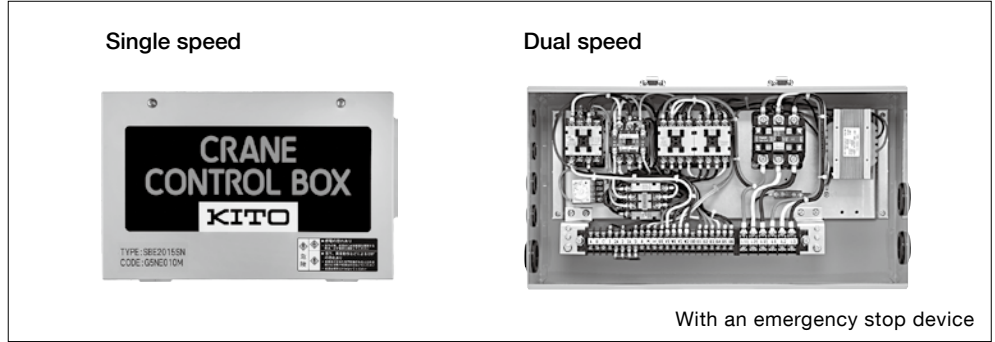

Type	Geared motor output	Power supply	Pendant control voltage	Rated current		Outline	Dimensions			Mass (kg/set)	
				Control box	Traveling		H	B	L		
Single Speed	SBE015SNH	~0.75kWx2	200V 50Hz	AC24V	50A	11A	Fig.A	230	140	410	7kg
	SBE015SNS		200~220V 60Hz								
	SBE030SNH	~1.5kWx2	200V 50Hz		75A	18A					
	SBE030SNS		200~220V 60Hz								
	SBE015SNX	~0.75kWx2	380V~415V 50Hz		50A	13A					
	SBE015SNS		440V 60Hz								
	SBE030SNX	~1.5kWx2	380V~415V 50Hz		50A	13A					
	SBE030SNS		440V 60Hz								
Dual Speed	SBE015SDNH	~0.75kWx2	200V 50Hz	AC24V	40A	11A	Fig.B	300	133	470	11kg
	SBE015SDNS		200~220V 60Hz								

- Models other than above control box is available as special specification. Please ask your KITO local partners.
- Environment: Ambient temperature: -20 to 40°C (No freezing) Installation site: Indoor, free of dust and corrosive gases.
- Protection class: IP20
- Color: Single Munsell 5Y7/1, Dual Munsell 6YR6/14

SOFTRUN DEVICE (Option)

This device electrically controls motor speed which enables the crane to accelerate smoothly in travel and minimizes load swing at start-up.

It is highly suited for handling high inertia loads or operating long span cranes.

- Easily installed between the control box and geared motor. Wiring connections are simple.
- Applicable for all models of motorized end carriages.

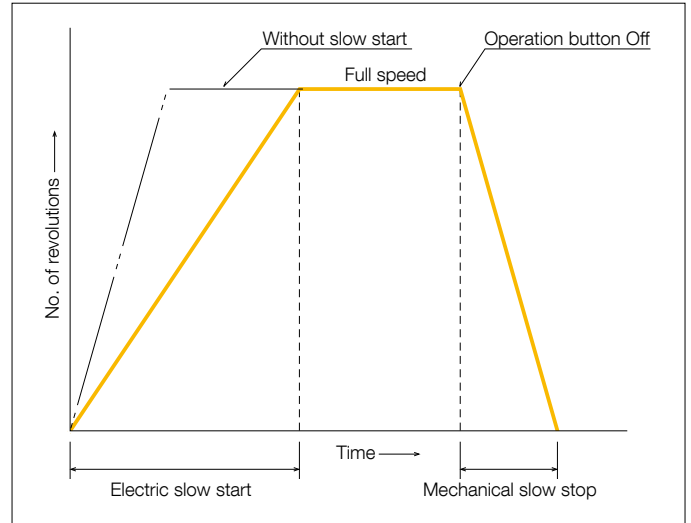

SOFTRUN

SOFTRUN uses a phase control system to adjust torque and the timer. The cushion time can be freely set between 1 and 5 seconds. It enables smooth start-up and operation without load swing. SOFTRUN uses a highly reliable semiconductor to maintain a long life.

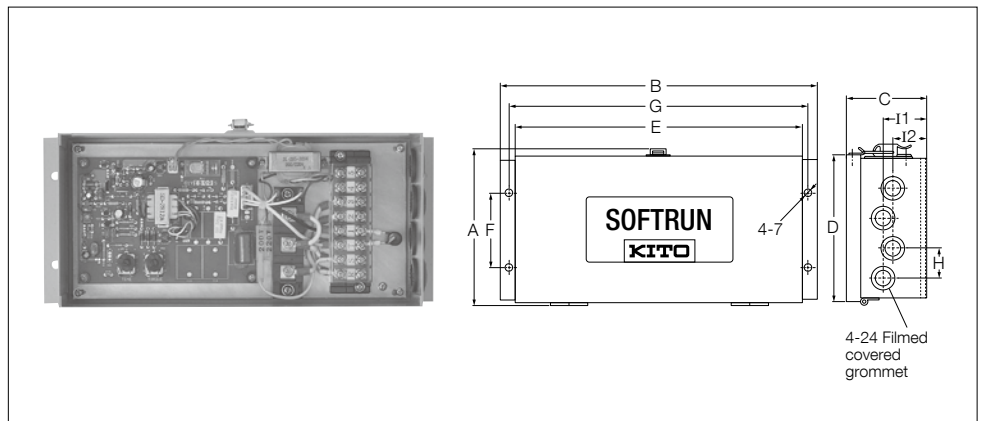

Type	Geared motor output	Rated current	Torque setting range	Timer range	Power supply		Dimensions (mm)										Mass (kg/set)				
					Rated voltage	Working voltage range	A	B	C	D	E	F	G	H	I1	I2					
SR150S-S	0.25 kWx2 0.4 kWx2 0.75 kWx2	7.5 A			200 V															2.5	
SR150S-Y					400 V																
SR150S-A					500 V																
SR300S-S	1.5 kWx2	15 A	0 to 10	1 to 5 sec	200 V	±10%	152	330	90	147	299	75	310	30	45	35					3
SR300S-Y					400 V																
SR300S-A					500 V																
SR300S-SX2	1.5 kWx4				200 V																
SR300S-SY2					400 V																
SR300S-SA2					500 V																

- Control method: Voltage drop start-up using T-phase control.
- Environment: Ambient temperature: -10 to 40 °C (No freezing) Installation site: Indoor, free of dust and corrosive gases.
- Dust and water protection: IP20 (Specified by I.E.C.)
- Color: Munsell 6YR6/14
- 220.440 V and 575 V / 60 Hz (for CSA) boxes available on request.

POWER SUPPLY CABLES AND ACCESSORIES

Power supply cable

Wiresx cross-sectional area	3Cx2 [□]	4Cx2 [□]	4Cx3.5 [□]	6Cx2 [□]	8Cx2 [□]	4Cx5.5 [□]	4Cx8 [□]	4Cx14 [□]	4Cx22 [□]	4Cx30 [□]
Cable diameter	ø11	ø12.3	ø14.2	ø14.5	ø16.8	ø17.5	ø19.5	ø24	ø30	ø36
Part No.	CTC3C x 2	CTC4C x 2	CTC4C x 3.5	CTC6C x 2	CTC8C x 2	CTC4C x 5.5	CTC4C x 8	CTC4C x 14	CTC4C x 22	CTC4C x 30
Type	Vinyl power supply cable (VCT)							Rubber power supply cable (2CT)		

Junction cable for electric chain hoist (ER2M) and rope hoist

Junction cable connecting the crane control box to the electric chain hoist. It is used for the power supply and operation circuits.

Wiresx cross-sectional area	7C composite cable (4C x 3.5 [□] + 3C x 0.75 [□])	9C composite cable (4C x 3.5 [□] + 5C x 0.75 [□])
Cable diameter	ø17.9	ø18.0
Part No.	CTC4C + 3C	CTC4C + 5C
Type	Vinyl power supply cable (VCT)	

Wire guide L

This guide is used to power the supply cable system (for low-head end carriage).

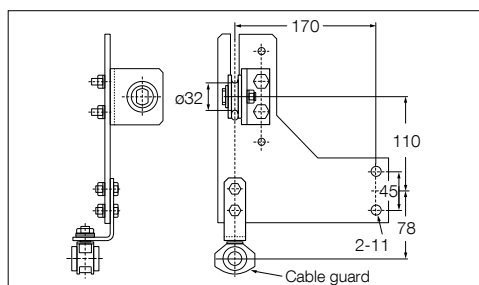

Type	Cable size		Cable guard
	Outer diameter	Wiresx cross-sectional area	
WGL16	ø14.2	4C x 3.5 [□]	CG16
WGL19	*ø17.0 to ø19.0	4C x 5.5 [□] 4C x 8 [□]	CG19

* Option

Wire guide O

This guide is used to power the supply cable system (for both overhead and low-head types).

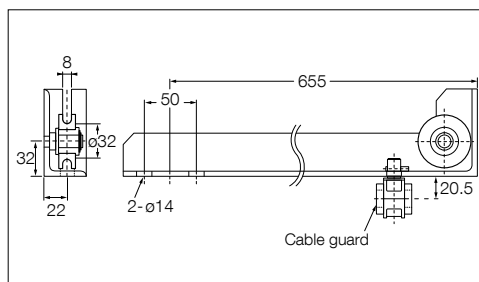

Type	Cable size		Cable guard
	Outer diameter	Wiresx cross-sectional area	
WGO16	ø14.2	4C x 3.5 [□]	CG16
WGO19	*ø17.0 to ø19.5	4C x 5.5 [□] 4C x 8 [□]	CG19

* Option

Wire bolt assembly

This bolt is used to fix messenger wires.

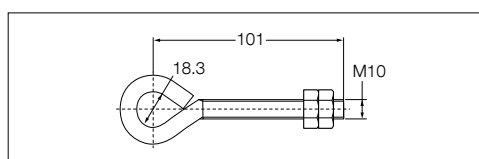

Type	With ø4 to ø6 wire clip
WB	

Allowable length (m) of power supply cable (200V)

IA	Cross-Section area (mm ²)						
	2 [□]	3.5 [□]	5.5 [□]	8 [□]	14 [□]	22 [□]	38 [□]
10	25	45	71	103			
15	17	30	47	69	121		
20	12	22	35	51	90		
25		18	28	41	72	114	
30			23	34	60	95	
35			20	29	51	81	111
40				25	45	71	97
45				23	40	63	86
50					36	57	77
60					30	47	64
70						40	55
80						35	48
90							43
100							38

How to identify allowable power supply cable

● Internal wiring specification JEAC8001-1995
120-1 Voltage drop

The voltage drop in low voltage lines is, as a rule, to be kept within 2% of the standard voltage of the trunk line and the branch circuit.

$$\text{Allowable length (m)} = \frac{1000}{30.8} \times \frac{\text{Cross-sectional area of single wire (mm}^2\text{)} \times \text{rated voltage} \times 0.02}{I A}$$

I A : Electric chain hoist or rope hoist
Rated current + Rated current of travel motor x 2

CABLE HANGERS

Angled hanger

This hanger uses an angle steel to hang power supply cables. The THLP type is used to hang push-button cord.

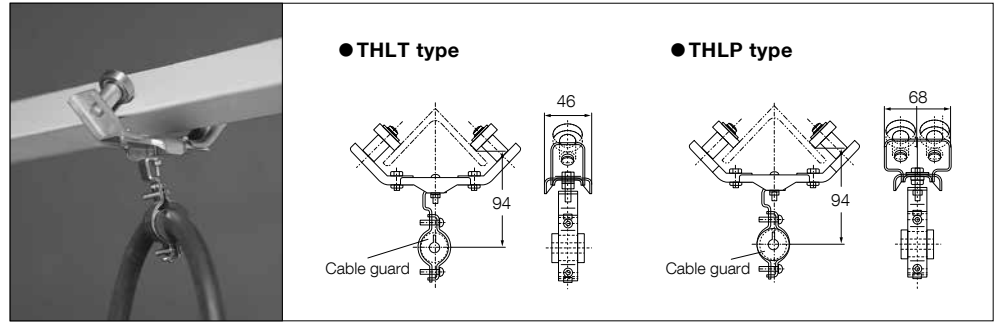

Type	Angle steel width	Cable size
THLT26S-75	L-50x50x6 to L-75x75x9	ø10 to ø26
THLP26S-75		

T-type hanger for wire rope hoists

This hanger is used to hang power supply cables and is suited for all sizes of cable and rails.

- Suited for hanging dynamic and operation cables for rope hoists.

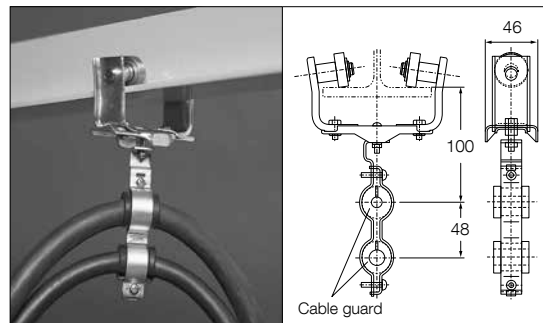

Type	Rail width	Cable size	
		Upper	Lower
THI19W-100	76 to 152	ø10 to ø22	
THI19W-175	127 to 178		
THI26W-100	76 to 152	ø22.1 to ø26	ø10 to ø22
THI26W-175	127 to 178		

T-type hanger for electric chain hoist (ER2M)

This hanger is used to hang power supply cables. It is applicable for all sizes of cable and rail widths, and is suited for compound cables.

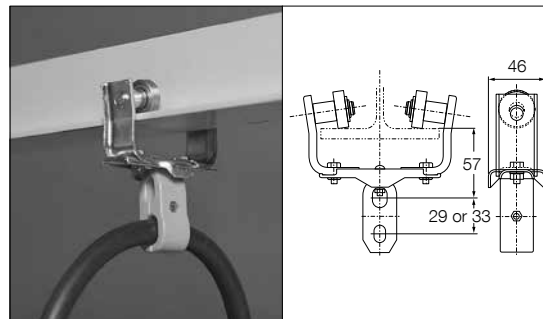

Type	Rail width	Cable size
TTH14S-100V	76 to 152	ø11 to ø13 or ø13 to ø15
TTH14S-175V	127 to 178	
TTH19S-100V	76 to 152	ø15 to ø17 or ø18 to ø20
TTH19S-175V	127 to 178	
TTH21S-100V	76 to 152	ø15 to ø17 or ø20 to ø22
TTH21S-175V	127 to 178	

Cable hanger

This hanger is used to hang power supply cables with messenger wires.

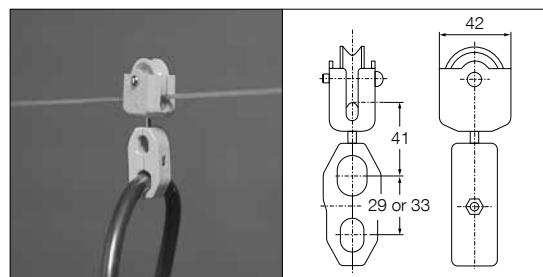

Type	Messenger wire	Cable size
CH14S		ø11 to ø13 or ø13 to ø15
CH17S		ø17 to ø19 or ø18 to ø20
CH19S	ø4 to ø6	ø15 to ø17 or ø18 to ø20
CH21S		ø15 to ø17 or ø20 to ø22

Cable guard

This guard is used to protect cables strung from T-type and angled hangers.

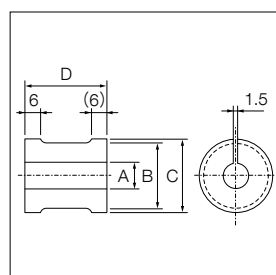

Type	Cable size	øA	øB	øC	D
CG13	ø10 to ø13	10	25		
CG16	ø13.1 to ø16	13			
CG19	ø16.1 to ø19	16	26	28	32
CG22	ø19.1 to ø22	19			
CG26	ø22.1 to ø26	22	34	37	

CRANE GIRDER ALLOWABLE SPAN

Single Rail (JIS)

Girder section	Dimensions A x B x t ₁ x t ₂	(kg/m)	Allowable span (m)								
			500 kg	1.0 t	1.5 t	2.0 t	2.5 t	3.0 t	5.0 t	7.5 t	10 t
 I-beam	I-200 x 100 x 7 x 10	26	6.0	4.6							
			6.0	4.6							
	I-250 x 125 x 7.5 x 12.5	38.3	8.6	6.7	5.5	4.5	4.0				
			8.3	6.1							
	I-250 x 125 x 10 x 19	55.5	11.2	8.2	6.9	6.0	5.4	4.9			
			11.2	8.2	6.9	6.0	5.4	4.9			
	I-300 x 150 x 8 x 13	48.3	10.2	9.0	6.8	6.1	5.6	4.9			
			10.0	7.6							
	I-300 x 150 x 10 x 18.5	65.5	11.6(11.2)	10.2	8.5	7.7	6.8	6.2	3.8		
			11.6(11.2)	10.2	8.5	7.4	6.7	6.4	4.3		
	I-300 x 150 x 11.5 x 22	76.8	11.6(11.2)	11.2	9.4	8.2	7.5	6.9	5.4		
			11.6(11.2)	11.2	9.4	8.2	7.5	6.9	5.0		
	I-350 x 150 x 9 x 15	58.5	11.2	9.4	7.8	6.9	6.4	6.0	3.6		
			11.0	9.0	7.7						
	I-350 x 150 x 12 x 24	87.2	11.6(11.2)	11.6(11.2)	11.3(11.2)	9.9	9.0	8.3	6.6	4.5	
			11.6(11.2)	11.6(11.2)	11.3(11.2)	9.9	9.0	8.3	6.1	4.2	3.1
I-400 x 150 x 10 x 18	72	11.6(11.2)	11.0	9.3	8.3	7.6	7.2	5.6			
		11.6(11.2)	10.6	8.7	8.1	7.5	7.1	5.1			
I-400 x 150 x 12.5 x 25	95.8	11.6(11.2)	11.6(11.2)	11.6(11.2)	11.3(11.2)	10.3	9.2	6.8	5.2	3.9	
			11.6(11.2)	11.6(11.2)	11.2	9.4	8.7	6.6	4.8	3.6	
I-450 x 175 x 11 x 20	91.7	11.6(11.2)	11.6(11.2)	11.6(11.2)	10.5	9.6	8.8	6.8	5.6		
			11.6(11.2)	11.0	10.7	9.9	9.3	6.8			
I-450 x 175 x 13 x 26	115	11.6(11.2)	11.6(11.2)	11.6(11.2)	11.6(11.2)	11.6(11.2)	11.1	8.5	6.8	5.4	
					11.6(11.2)	11.4(11.2)	10.5	8.1	6.5	4.8	

■: For kito electric hoist.







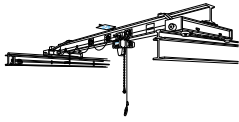

■: For kito wire rope hoist.

- The above data is calculated according to the crane standard in Japan: Deflection=Within 1/1000 x span. Allowable bending stress=Within 1390 kg/cm²
- A stop drawing for the girder available on request.
- The figures in parentheses are data for Low-head cranes.

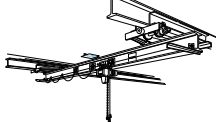
Kito offers a variety of systems that are created by combining Kito Chain Sling 100 products with Kito's motorized and manual hoists and cranes. Special specifications are realized as order-made products.

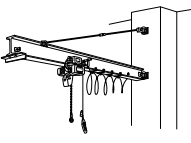
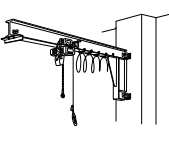
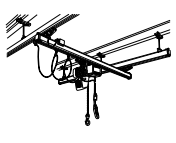

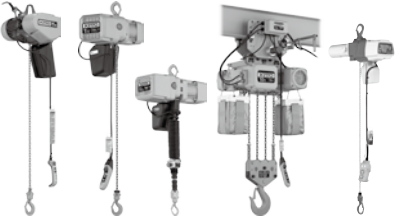
Reference Examples of Special Specification Systems

In the situation where you wish to transport unique work pieces with high efficiency using dedicated slings, Kito Chain Sling 100 "Special Specification" products will support every requirement.

<p>Each Type of Crane</p> <p>+</p>	 <p>Overhead Crane (Single Girder)</p>	 <p>Overhead Crane (Double Girder)</p>	 <p>Low-head Crane</p>	 <p>Gantry Crane</p>
	 <p>Jib Crane Pillar Type (JP Type)</p>	 <p>Jib Crane Wall Type (JW Type)</p>	 <p>Jib Crane Wall Type (LJW Type)</p>	 <p>Light Crane (Steel Rail)</p>
<p>Each Type of Hoist</p> <p>+</p>	 <p>Wire Rope Hoist</p>	 <p>Electric Chain Hoist ER2/EQ/ED</p>		 <p>Chain Hoist M3/CX</p>

Kito Chain Sling 100 Special Specifications

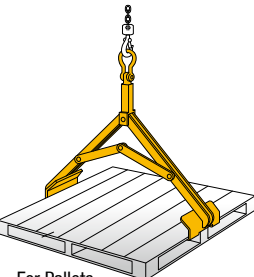
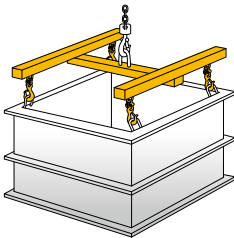
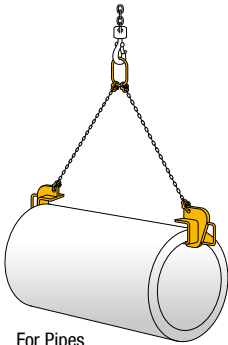
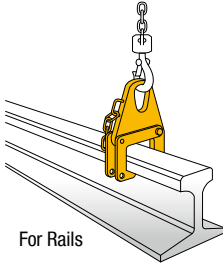
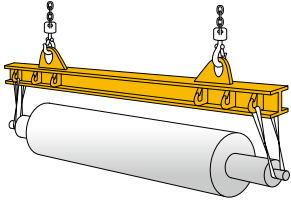
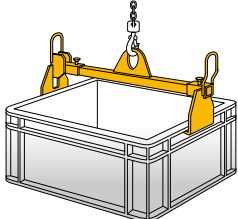
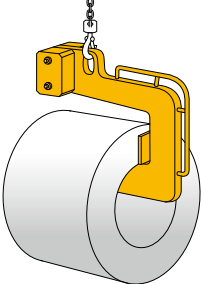
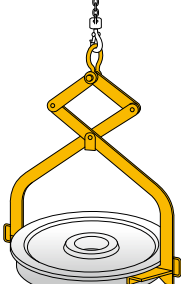
Products are order-made to match applications. (Several examples are introduced below)

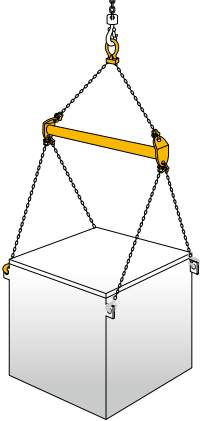
 <p>For Pallets</p>	 <p>For Short Headroom Types</p>	 <p>For Pipes</p>	 <p>For Rails</p>	 <p>For Balance Beams/Standard Types</p>
 <p>For Plastic Containers</p>	 <p>For Coils</p>	 <p>For Train Wheels</p>	 <p>For Coils</p>	 <p>For Balance Beams/Distance Bars</p>



Head Office & Factory

2000 Tsuijijarai Showa-Cho, Nakakoma-Gun, Yamanashi 409-3853, Japan
TEL: +81-55-275-7521 FAX: +81-55-275-6162

Tokyo Head Office

SHINJUKU NS Bldg. 9F, 2-4-1 Nishi-Shinjuku, Shinjuku-ku, Tokyo 163-0809, Japan
TEL: +81-3-5908-0180 FAX: +81-3-5908-0189
www.kito.co.jp/en KITO Global Website: kito.com

International Sales Subsidiaries

U.S.A.

Harrington Hoists, Inc.

401 West End Avenue, Manheim, PA 17545, U.S.A.
TEL: +1-717-665-2000 FAX: +1-717-665-2861
www.harringtonhoists.com/

PEERLESS INDUSTRIAL GROUP, INC.

1416 East Sanborn St. Winona, MN 55987, U.S.A.
TEL: +1-800-873-1916 FAX: +1-800-356-1149
www.peerlesschain.com/

CANADA

KITO CANADA INC.

309-3815 1st Ave., Burnaby, BC V5C 3V6, Canada
TEL: +1-604-291-9955 FAX: +1-604-294-8855
www.kito.ca/

BRAZIL

KITO DO BRASIL COMÉRCIO DE TALHAS E GUINDASTES LTDA

Unidade 38 do CLE – CENTRO LOGÍSTICO EMBU
Rua José Semião Rodrigues Agostinho, 1370,
Bairro Água Espraiada – Embu das Artes, SP, Brasil
TEL: +55-11-3253-1000 FAX: +55-11-3253-1008
http://www.kito.com/br/

GERMANY

Kito Europe GmbH

Heerdter Lohweg 93, D-40549 Düsseldorf, Germany
TEL: +49-(0)211-528009-00 FAX: +49-(0)211-528009-59
www.kito.net/

ITALIA

Kito Chain Italia S.r.l.

Via Giuseppe Verdi 11, 33018, Tarvisio (Ud), Italia
TEL: +39-(0)428-4171 FAX: +39-(0)428-417301

AUSTRALIA

KITO PWB

441 Grimshaw Street, Bundoora, VIC 3083, Australia
TEL: +61-1300-792-262 FAX: +61-3-9467-7290
www.pwbandor.com.au/

CHINA

JIANGYIN KITO CRANE CO., LTD.

18 Cheng Jiang East Road, Jiang Yin, Jiang Su 214429, China
TEL: +86-510-86199700 FAX: +86-510-86196633
www.kaicheng.com/

SHANGHAI KITO TRADING CO., LTD.

Room 11J, Zao-Fong Universe Building,
No1800 ZhongShan West Road Shanghai 200235, China
TEL: +86-21-54488935 FAX: +86-21-54488937
www.kito.com.cn/

TAIWAN

KITO TAIWAN CO., LTD.

12F-1, 128c sec. 3, Ming-Shen East Road, Taipei, Taiwan 10596
TEL: +886-2-2719-7616 FAX: +886-2-2719-6900
www.tw.kito.com/

KOREA

KITO KOREA CO., LTD.

3Dong 903, 15, Pangyo-Ro 228Beon-gil, Bundang-gu,
Seongnam-si, Gyeonggi-do, Korea 13487
TEL: +82-31-600-7450 FAX: +82-31-600-7469
www.kito.kr/

THAILAND

SIAM KITO CO., LTD.

205 M.2, T.Klongtumru, A.Muangchonburi, Chonburi 20000, Thailand
TEL: +66-3819-5711 FAX: +66-3846-8195
www.siamkito.co.th/

INDIA

Armsel MHE Pvt. Ltd.

Sy No 118/2 of Jakkur Village, 80 Feet Road, Jakkur Post,
Yelahanka Hobli, Bengaluru – 560064, Karnataka, India
TEL: +91-80-3357-2525
Mail: enquiry@armsel.com
www.armsel.com

INDONESIA

PT. KITO INDONESIA

JL. Kenari Raya Block G2-10A, Delta Silicon 5, Lippo Cikarang, Bekasi, Indonesia
TEL: +62-21-2961-2150 FAX: +62-21-2961-2151
https://id.kito.com/id/

- The functions and performance of the products mentioned in the catalog have been designed based on the related regulations and standards. If they are used for other than their intended purposes such as being integrated into your equipment, we will not take any responsibility for accidents attributable to their unintended usages as well as guarantee their performance and functions. Never remodel our products.
- When you want to use our products for special purposes, consult us in advance.
- When you want to export our products, consult us in advance. There are different standards and regulations from one destination to another.
- It is prohibited to reprint, copy or divert all the information in this catalog (product patents, trademarks, photos, designs, copies, illustrations, etc.) without our consent.
- The specifications in this catalog are partly subject to change without prior notice.
- Product specifications may vary depending on the country. For more details please contact the nearest KITO dealer.

Distributed by:



This printed paper is made from the trees harvested in well-managed forests.